

THYROID HORMONE TUTORIAL: THE THYROID AND THYROID HORMONES

Jack DeRuiter

I. INTRODUCTION

This tutorial is intended to supplement the chapter "Thyroid Disorders" in the *Pharmacotherapy: a Pathophysiologic Approach*. The thyroid hormones, thyroxine (3,5,3',5'-tetraiodo-L-thyronine, T₄) and triiodothyronine (3,5,3',-triiodo-L-thyronine T₃) are secreted by the thyroid gland and are critically important for:

- normal development of CNS in infants
- skeletal growth and maturation in children
- normal function of multiple organ systems in adults

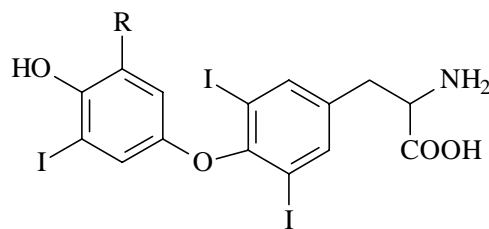

Triiodothyronine (T₃): R = H

Thyroxine (T₄): R = I

The physiologic actions of thyroid hormones are discussed in more detail in the sections that follow. It is important to understand the role of thyroid in human physiology and disease since *thyroid disorders are one of the most common endocrine disorders encountered in clinical practice*.

II. STRUCTURE OF THE THYROID GLAND

During fetal development, the thyroid originates in the back of the tongue before migrating to the front of the neck, just below the larynx. The largest gland in the neck, a normal thyroid is a firm, reddish brown, smooth gland and weighs less than one ounce and is made up of two large lobes that lie along either side of the trachea. These lobes are joined together by a narrow band of thyroid tissue, known as the isthmus. It is surrounded by fibrous capsule that projects into the gland, dividing it into many small lobules. The thyroid has very high blood flow based on weight of organ and consists of closely packed follicles surrounded by capillaries.

The follicles are spherical filled with colloid and surrounded by layer of cuboidal epithelial cells. The colloid is proteinacious material composed of thyroglobulin and stored thyroid hormone. The "inactive gland" has large follicles with lining cells are flat and a large quantity of colloid. The active thyroid gland has small follicles with lining is cuboidal or columnar lining, scanty colloid and scalloped edges forming reabsorption lacunae.

The follicular cells have several functions including the collection and transport iodine to colloid, the synthesize thyroglobulin and the secretion of thyroglobulin to release thyroid hormones from engulfed colloid and secrete into circulation.

III. SYNTHESIS, STORAGE AND SECRETION OF THYROID HORMONE

A. Formation of Thyroid Hormones

The thyroid hormones T₃ and T₄ are formed in a large prohormone molecule, thyroglobulin, the major component of the thyroid and more precisely of the colloid. Thyroglobulin is synthesized in the thyroid follicular cells and secreted into the lumen of the follicles. It is an iodinated glycoprotein (660,000 daltons) made up of two identical subunits, each with a molecular weight of 330,000 daltons. It is of special importance because it is necessary for the synthesis of thyroid hormones and represents their form of storage.

The formation of the thyroid hormones depends on an exogenous supply of iodide. The thyroid gland is unique in that it is the only tissue of the body able to accumulate iodine in large quantities and incorporate it into hormones. The formation of thyroid hormones involves the a complex sequence of events including: (1) active uptake of iodide by the follicular cells, (2) oxidation of iodide and formation of iodotyrosyl residues of thyroglobulin, (3) formation of iodothyronines from iodotyrosines, (4) proteolysis of thyroglobulin and release of T₄ and T₃ into blood, and (5) conversion of T₄ to T₃. These processes are summarized in Figures 1 and 2 and described in more detail below. Figure 1 provides an overview of thyroid hormone biosynthesis and utilization, while Figure 2 provides structural details of the key biochemical reactions.

B. Active Uptake of Iodide by Follicular Cells

The first step in the synthesis of the thyroid hormones is the uptake of iodide from the blood by the thyroid gland. An adequate intake of iodide is essential for the synthesis of sufficient thyroid hormone. **Thyroid hormone synthesis requires daily intake of 150mcg iodine (normal US daily intake = 500mcg).**

Dietary iodine is converted to iodide and almost completely absorbed from the gastrointestinal tract. Blood iodine is present in a steady state in which dietary iodide, iodide "leaked" from the thyroid gland, and reclaimed hormonal iodide provide the input, and with thyroidal uptake, renal clearance, and a small biliary excretion providing the output. The thyroid gland regulates both the fraction of circulating iodide it takes up and the amount of iodide that it leaks back into the circulation. A general scheme for iodide metabolism is shown in Figure 3.

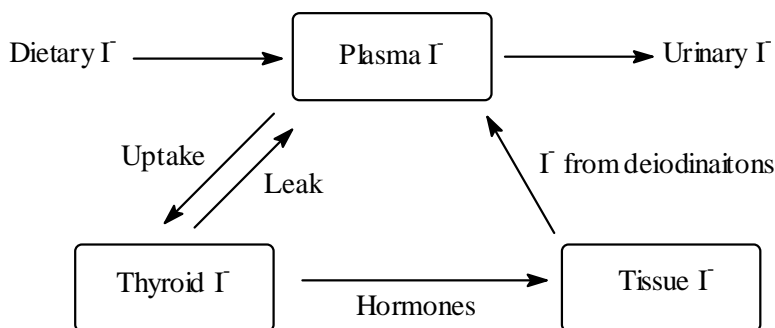

Figure 3: Iodide metabolism

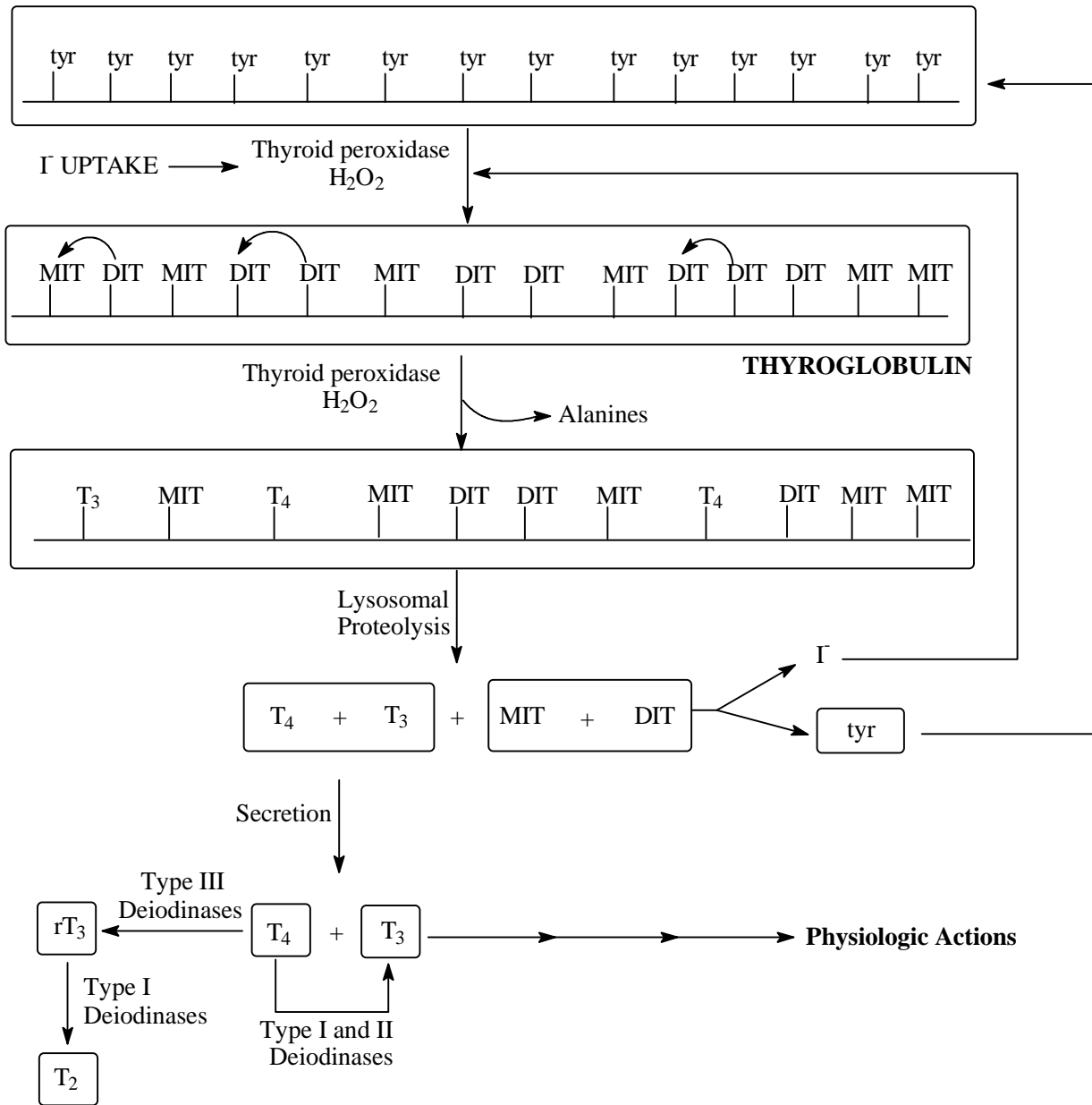

Figure 1: Overview of Thyroid Hormone Biosynthesis

Endocrine Pharmacotherapy Module: Thyroid Section, Summer, 2001

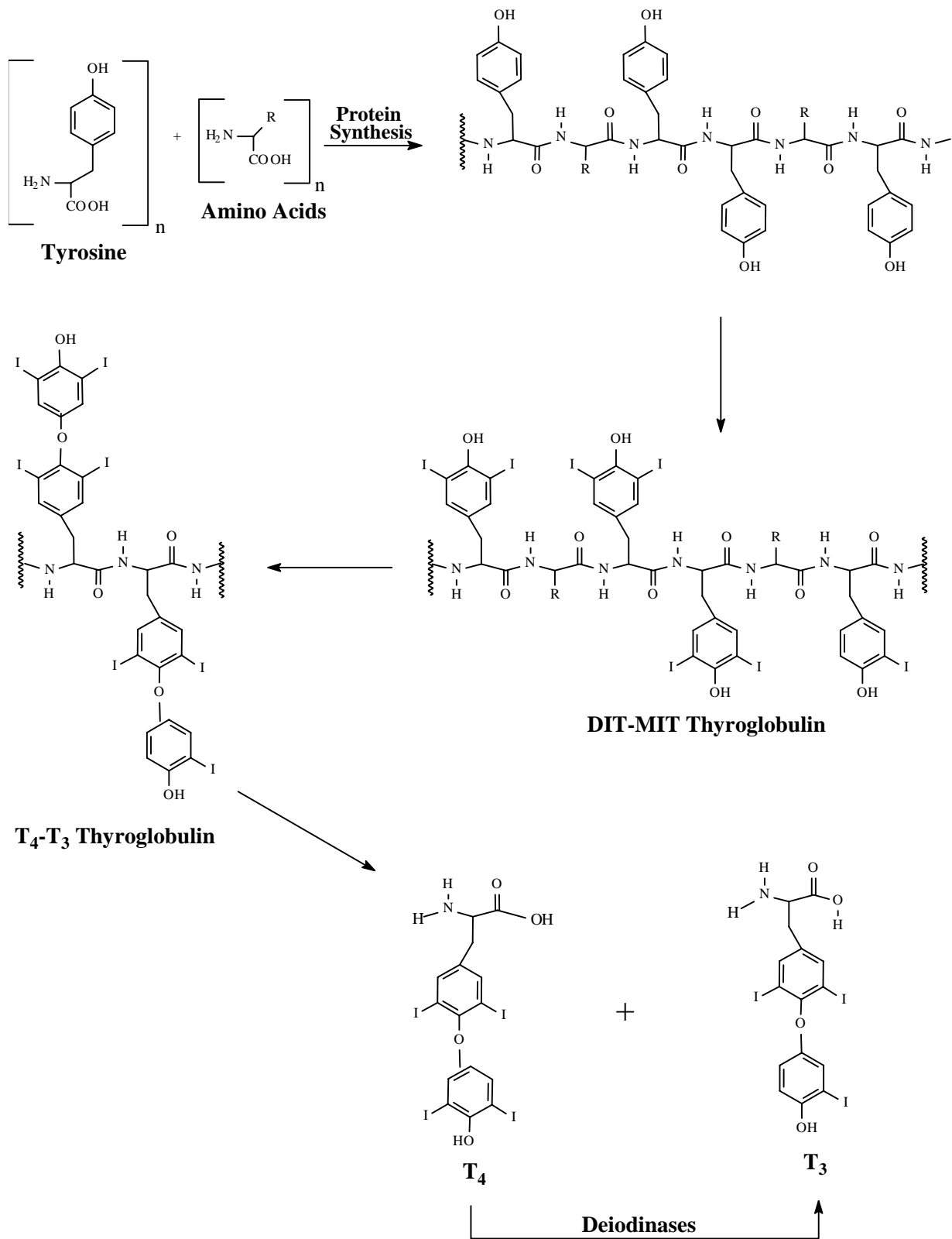

Figure 2: Thyroid Hormone biosynthesis: Structural Details

The mechanism enabling the thyroid gland to concentrate blood iodide against a gradient into the follicular cell is sometimes referred to as the iodide pump. The iodide pump is 65 kDa cell membrane protein acting as secondary active transport dependent on $\text{Na}^+\text{-K}^+$ ATPase for energy and is stimulated by thyroid stimulating hormone (TSH – see below). Normally 120mcg/d of iodide enters thyroid and 80mcg/d is incorporated into T_3 and T_4 , and the rest is excreted in urine. The iodide pump mechanism establishes a ratio of thyroid iodide to serum iodide (T/S ratio) of 20:1 under basal conditions but of more than 100:1 in hyperactive gland. Iodide uptake may be blocked by several inorganic ions, such as thiocyanate and perchlorate. Because iodide uptake involves concurrent uptake of potassium, it can also be blocked by cardiac glycosides that inhibit potassium.

C. Oxidation of Iodide and Formation of Iodotyrosines.

The second step in the process is a concerted reaction in which iodide is oxidized to an active iodine species that, in turn, iodinate the tyrosyl residues of thyroglobulin (Figures 1 and 2). The reaction takes place at the border of the lumen ("apical border") using iodide concentrated within the follicle and is catalyzed by thyroid peroxidase (TPO) in the presence of iodide and hydrogen peroxide. Although DIT residues constitute the major products, some MIT peptides are also produced. A mechanism proposed for this reaction is shown in Figure 4.

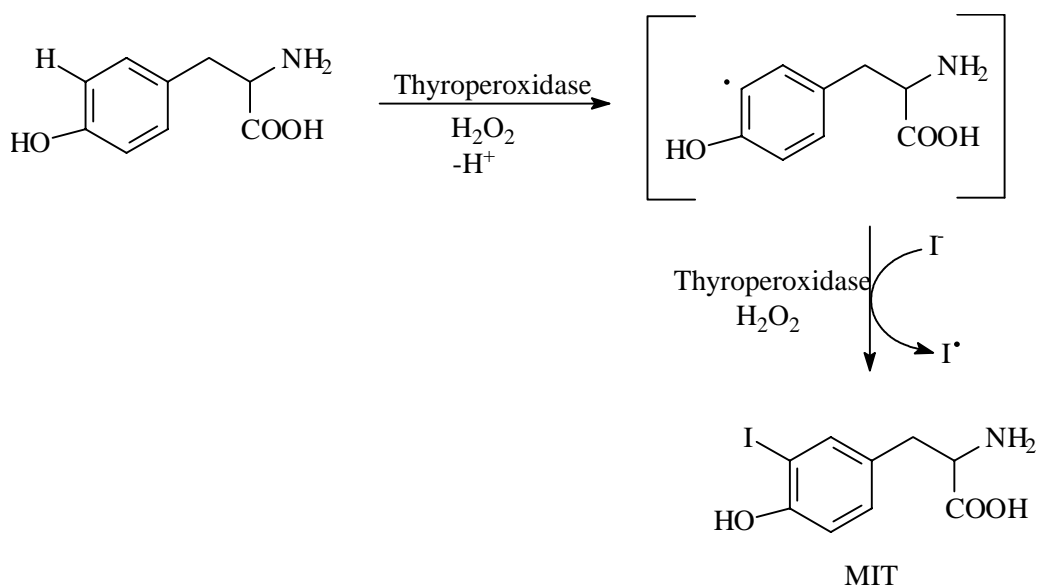

Figure 4: Proposed Mechanisms for the TPO mediated Iodination of Tyrosine

In the thyroid, intracellular iodide taken up from blood is bound in organic form in a few minutes so less than 1 percent of the total iodine of the gland is found as iodide. Therefore, inhibition of the iodide transport system requires blockade of organic binding. This can be achieved by the use of antithyroid drugs, of which n-propyl-6-thiouracil and 1-methyl-2-mercaptoimidazole are the most potent (see later sections).

D. Coupling of Iodotyrosine Residues.

This reaction takes place at thyroglobulin and involves the coupling of two DIT residues or one DIT with one MIT residue (each with the net loss of alanine) to produce peptide-containing residues of the two major thyroid hormones T_4 and T_3 (Figures 1 and 2). Some DIT's combine with MIT's to form triiodothyronine (T_3) and reverse T_3 (see later section). It is believed that these reactions are catalyzed by the same peroxidase that effects the iodination and, therefore, can be blocked by compounds such as thiourea, thiouracils, and sulfonamides (see later sections on Drugs).

E. Proteolysis of Thyroglobulin and Release of Iodothyronines.

The release of thyroid hormones from thyroglobulin is a process that involves endocytosis of colloid droplets into the follicular epithelial cells and subsequent proteolysis (proteases) of the contents of these droplets by the digestive enzymes of the lysosomes/phagosomes of the follicular cells. Phagosomes engulf colloid and their proteases hydrolyze peptide bonds releasing MIT, DIT, T_3 , and T_4 . MIT and DIT, although formed, do not leave the thyroid. Instead, they are selectively metabolized by thyroid deiodinase to tyrosine and iodine which are recycled to the colloid, and the iodide liberated is reincorporated into protein. T_3 and T_4 are secreted by the cell into the circulation (Figures 1 and 2). Each day, thyroid secretes 80mcg T_4 and 4mcg T_3 .

III. THYROID HORMONE TRANSPORT, METABOLISM AND EXCRETION

A. Conversion of Thyroxine to Triiodothyronine.

Although T_4 is by far the major hormone secreted by the thyroid (about 8 to 10 times the rate of T_3), it is usually considered to be a prohormone. Because T_4 has a longer half-life, much higher levels of T_4 than T_3 are in the circulation. The enzymatic conversion of T_4 to T_3 is an obligate step in the physiologic action of thyroid hormones in most extrathyroidal tissues. In the peripheral tissues, about 33% of the T_4 secreted undergoes 5'-deiodination to give T_3 , and another 40% undergoes deiodination of the inner ring to yield the inactive material rT_3 . The deiodination of T_4 is a reductive process catalyzed by a group of enzymes named iodothyronine deiodinases referred to as deiodinases and symbolized by D, found in a variety of cells. These reactions are summarized in Figures 1 and 2.

Three types of deiodinases are currently known and are distinguished from each other primarily based on their location, substrate preference, and susceptibility to inhibitors. Type I deiodinase is found in liver and kidney and catalyzes both inner ring and outer ring deiodination (i.e., T_4 to T_3 and rT_3 to 3,3'- T_2). Type II deiodinase catalyzes mainly outer ring deiodination (i.e., T_4 to T_3 and T_3 to 3,3'- T_2) and is found in brain and the pituitary. Type III deiodinase is the principal source of rT_3 and is present in brain, skin, and placenta.

B. Transport of Thyroid Hormones in Blood

The iodothyronines secreted by the thyroid gland into thyroid vein blood are of limited solubility. They equilibrate rapidly, however, through noncovalent association with the plasma proteins

thyroxine-binding globulin (TBG), thyroxine-binding prealbumin (TBPA), and albumin. The thyroid hormones form a 1:1 complex with TBG, the major carrier protein in humans with a molecular weight of 63,000 daltons. The plasma proteins involved in thyroid hormone transport and their approximate association constants (K_a) for T_3 and T_4 are shown in the Table 1 below. This table indicates that TBG has a high affinity for T_4 (K_a about 10^{10} M) and lower affinity for T_3 . TBPA and albumin also transport thyroid hormones in the blood; prealbumin has K_a values of about 10^7 and 10^6 M for T_4 and T_3 . The equilibrium between the free hormone and protein bound hormone determines the accessibility of the free thyroid hormone for the tissue receptors as well as to peripheral sites where biotransformation takes place.

Table 1: Plasma proteins involved in thyroid hormone transport:

Protein	Conc (mg/dl)	K_a for T_4	% T_4 Bound	K_a for T_3	% T_3 Bound
TBG	1.5	10^{10}	75	10^9	70
TBPA	25.0	10^7	15	10^6	----
Albumin	4000.0	10^6	10	10^5	30

The lower binding affinity for T_3 to plasma proteins may be an important factor in the more rapid onset of action and in the shorter biologic half-life for T_3 . *Drugs and disease states can effect the availability of thyroid binding proteins as illustrated in Table 2 describing the effects of physiological states on plasma thyroid binding proteins and T_3 and T_4 levels*

Table 2: Summary of the effects of physiological states on plasma thyroid binding proteins and T_3 and T_4 levels

Condition	Concentrations of Binding Proteins	Total Plasma T_4 , T_3 , RT_3	Free Plasma T_4 , T_3 , RT_3	Plasma TSH	Clinical State
Primary hyperthyroidism	Normal	High	High	Low	Hyperthyroid
Primary hypothyroidism	Normal	Low	Low	High	Hypothyroid
Drugs (estrogens, methadone, heroin, perphenazine, clofibrate), pregnancy, acute and chronic hepatitis, acute intermittent porphyria, estrogen-producing tumors, idiopathic, hereditary	High	High	Normal	Normal	Euthyroid
Drugs (glucocorticoids, androgens, danazol, asparaginase), acromegaly, nephrotic syndrome, hypoproteinemia, chronic liver disease (cirrhosis), testosterone-producing tumors, hereditary	Low	Low	Normal	Normal	Euthyroid

Thyroid hormones are taken into cells by facilitated diffusion or by active transport secondary to a sodium gradient. Once in the cell, thyroid hormones bind to cytosolic binding proteins and are not readily available for exchange with plasma hormones. T_3 and T_4 are not evenly distributed in body cells: A great part of T_4 is stored in liver and kidney, whereas most T_3 appears in muscle and brain.

C. Metabolism and Excretion

As discussed earlier, T₄ is considered to be a prohormone, and its peripheral metabolism occurs in liver, kidney, & other tissues in two ways: outer ring deiodination by the enzyme 5'-D, which yields T₃, and inner ring deiodination by the enzyme 5-D, which yields rT₃, for which there is no known biologic function (Figure 5). In humans, deiodination is the most important metabolic pathway of the hormone, not only because of its dual role in the activation and inactivation of T₄, but also in quantitative terms: 87% of T₃ in circulation is formed from T₄.

Degradative metabolism of the thyroid hormones, apart from peripheral deiodination, occurs mainly in the liver, where both T₃ and T₄ are conjugated to form either glucuronide (mainly T₄) or sulfate (mainly T₃) through the phenolic hydroxyl group. The resulting iodothyronine conjugates are excreted via the bile into the intestine, where a portion is hydrolyzed by bacteria. It also undergoes marginal enterohepatic circulation and is excreted unconjugated in feces. T₄ is conjugated with sulfate in kidney and liver, and the T₄4'-O-sulfate, an excellent substrate for 5'-D, is believed to play a role in the regulation of T₄ metabolism.

Additional metabolism, involving side-chain degradation, proceeds by transamination, oxidative deamination, and decarboxylation to yield thyroacetic acid and thyroethanediol; also, cleavage of the diphenyl ether linkage has been detected both in vitro and in vivo. The reactions through which thyroid hormone is metabolized are summarized in Figure 5 (next page).

Endocrine Pharmacotherapy Module: Thyroid Section, Summer, 2001

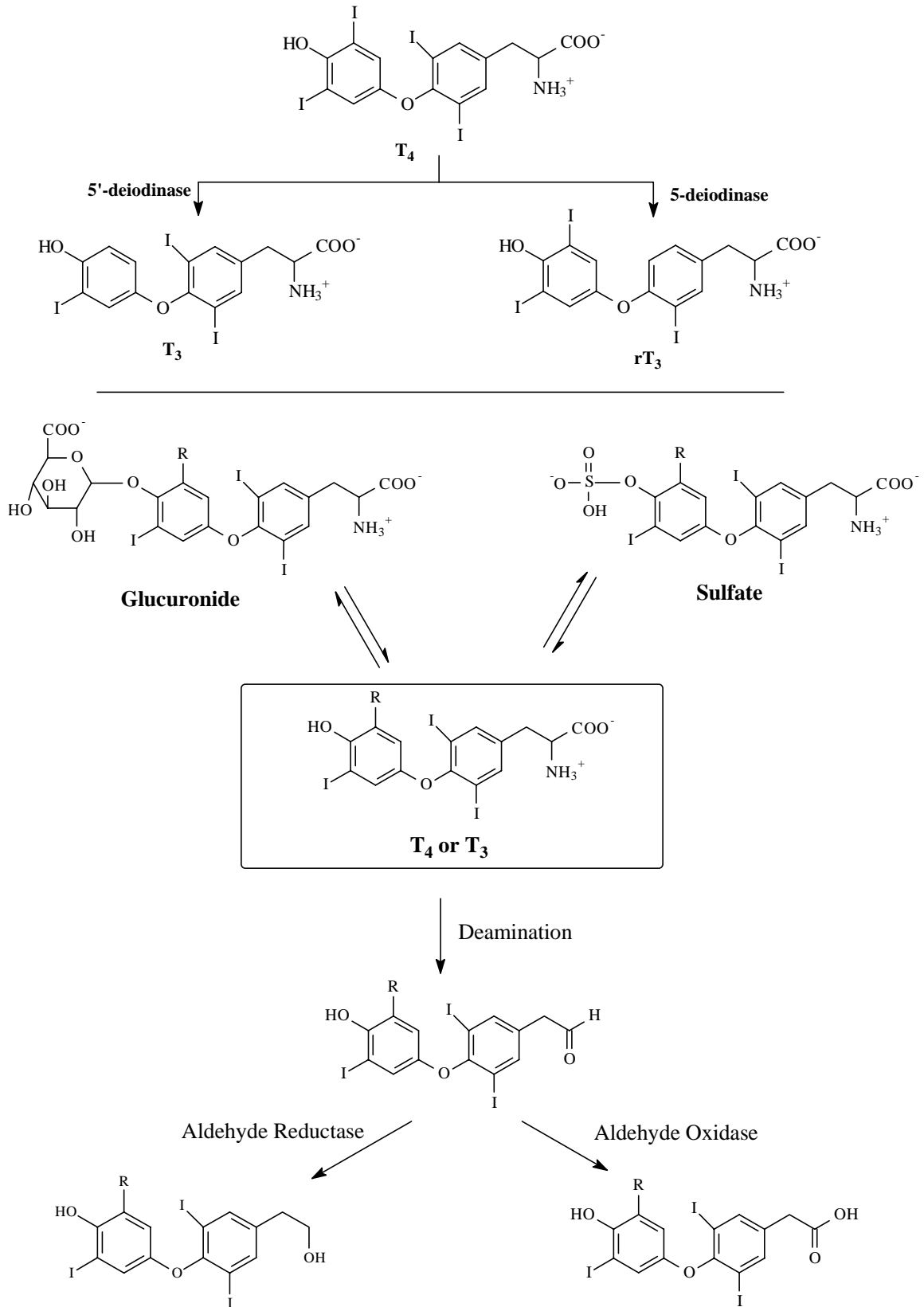

Figure 5: Thyroid Hormone Metabolism

IV. THYROID HORMONE SARs AND RECEPTOR BINDING

Through molecular modeling, x-ray crystallographic and nuclear magnetic resonance studies it has been shown that a perpendicular orientation of the planes of the aromatic rings of 3,5-diiodothyronines is favored to minimize interactions between the bulky 3,5-iodines and the 2',6'-hydrogens (Figure 6). In this orientation, the 3'- and 5'-positions of the ring are not conformationally equivalent, and the 3' iodine of T₃ could be oriented either distal (away from) or 5' proximal (closer) to the side chain-bearing ring. Because the activity of compounds such as 3',5-dimethyl-3,5-diiodothyronine had demonstrated that alkyl groups could replace the 3'- and 5'-iodine substituents, model compounds bearing alkyl groups in the 3'-position and alkyl or iodine substituents in the 5'-position (in addition to the blocking 2'-methyl group) were synthesized for biologic evaluation (Figure 6).

In addition to being perpendicular to the inner ring, the outer phenolic ring can adopt conformations relative to the alanine side chain, which would be *cis* or *trans*. In other words, the *cisoid* and *transoid* conformations result from the methine group in the alanine side chain being either *cis* or *trans* to the phenolic ring. Although the bioactive conformation of the alanine side chain in thyroid hormone analogs has not yet been defined, these conformations appear to be similar in energy because both are found in thyroactive structures determined by x-ray crystallography. The synthesis of conformationally fixed cyclic or unsaturated analogs may allow evaluation of the bioactivity of the two conformers.

An additional tool in structural analysis and analog design has been TBPA, a plasma protein that binds as much as 27% of plasma T₃. The amino acid sequence of the TBPA T₃ binding site is known, and the protein has therefore served as a model, although admittedly an approximate model, for the T₃ receptor. The TBPA model portrays the T₃ molecule as placed in an envelope near the axis of symmetry of the TBPA dimer. In this envelope, hydrophobic residues, such as those of leucine, lysine, and alanine, are near pockets accommodating the 3,5,3'- and 5'-positions of T₃, whereas the hydrophilic groups of serine and threonine, hydrogen bonded to water, are between the 3' substituent and 4' phenolic group. Taking this model into account, it has been suggested that 3'-acetyl-3,5-diiodothyronine might be a good analog or a good inhibitor of T₃ because the carbonyl group of the 3'-acetyl substituent would form a strong hydrogen bond with the 4'-phenolic hydrogen, preventing thereby its bonding with the hydrated residue of the putative receptor.

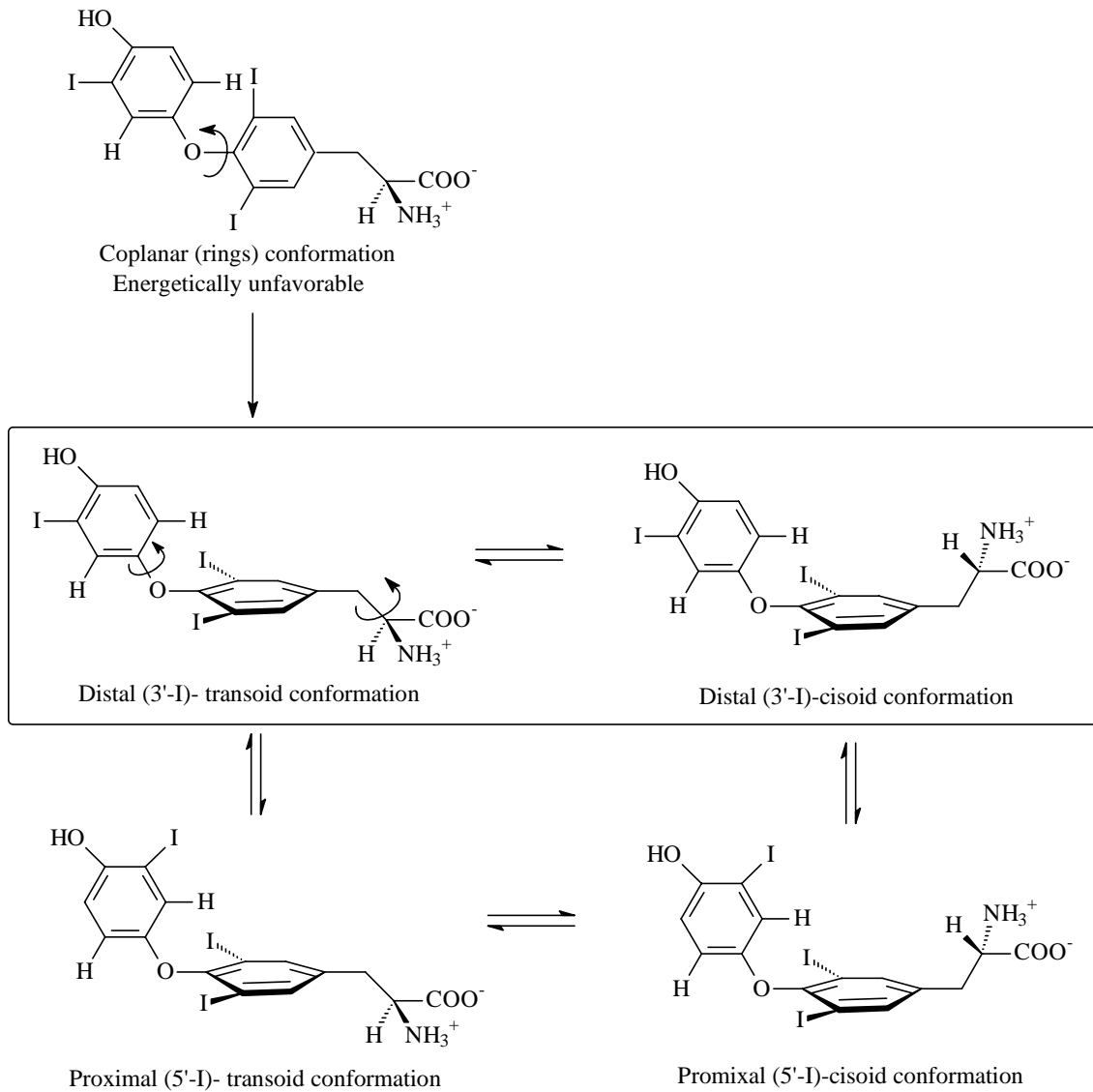

Figure 6: Thyroid hormone stereochemistry and conformation

V. REGULATION OF THYROID HORMONE FUNCTION, PHYSIOLOGIC ACTIONS AND PATHOPHYSIOLOGY

Thyroid-stimulating hormone (TSH) from the anterior pituitary increases all known activities of the thyroid gland to increase release of thyroid hormone. TSH is controlled by the hypothalamic peptide, thyrotropin-releasing hormone (TRH), following release into the hypothalamic portal system. Thyroid hormone release is controlled by an inverse feedback system on TRH and TSH release (see Figure 7). TSH is two subunit (alpha and beta) glycoprotein (211 AA). Its alpha subunit is identical to other pituitary hormones (FSH, LH, etc.) encoded on chromosome 6 and to hCG. The TSH beta subunit unique to TSH encoded on chromosome 1. TSH has a half-life = 60 minutes and typical plasma level are 0.4 - 4.8 mU/L in those with normal thyroid function. TSH binds to TSH-receptor (TSH-R) on the thyroid cell membrane and receptor is coupled to a G-protein system coupled to adenylate cyclase. Thus stimulation of the this receptor results in increased cAMP formation which mediates increases in uptake and transport of iodide, iodination of thyroglobulin, and synthesis of iodotyrosines. TSH binding to TSH-R also stimulates phospholipase C leading to thyroid cell hypertrophy. Chronic TSH stimulation causes entire gland to hypertrophy causing a goiter.

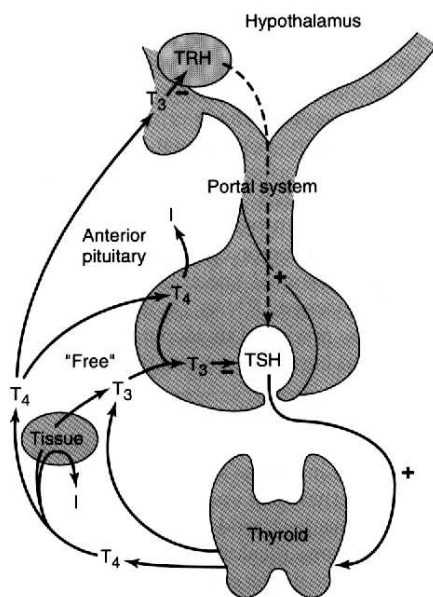

Figure 7: Regulation of Thyroid Hormone Production

The regulation of thyroid hormone production as well as the physiologic actions and disease states associated with thyroid overproduction (hyperthyroidism) or underproduction (hypothyroidism) are discussed in more detail in the chapter "Thyroid Disorders" in the *Pharmacotherapy: a Pathophysiologic Approach*. Some of the major physiological actions of the thyroid hormones and pathophysiology of thyroid-related disease states are summarized below:

A. PHYSIOLOGICAL EFFECTS OF THYROID HORMONES:

Thyroid hormones, especially T₃, enter tissue cells by diffusion or specific transport where they bind to two different receptors nuclear receptors designated as hTR-α1 and hTR-β1. The T₃-receptor complex then binds DNA via “zinc fingers” and this produces a change in the expression of a variety of genes that encode enzymes that control cellular metabolism and function.

Thyroid hormones effect normal growth and development (particularly in bone and CNS), help regulate lipids (adipose tissue), increase absorption of carbohydrates from intestine, increase protein breakdown in muscle, increases dissociation of O₂ from hemoglobin by increasing RBC 2,3-diphosphoglycerate (DPG). They also stimulate increased O₂ consumption and metabolic rate in most metabolically active tissues (exceptions are brain, testes, uterus, lymph nodes, spleen and anterior pituitary). Thus the thyroid hormones increase cellular respiration and thereby increase the basal metabolic rate (BMR) The general physiologic actions under control of the thyroid hormones are shown in Table 3:

Table 3. Physiological Actions of the Thyroid Hormones

Target Tissue	Effect	Mechanism
Heart	Chronotropic	Increase number and affinity of beta-adrenergic receptors.
	Inotropic	Enhance responses to circulating catecholamines. Increase proportion of alpha myosin heavy chain (with higher ATPase activity).
Adipose tissue	Catabolic	Stimulate lipolysis.
Muscle	Catabolic	Increase protein breakdown.
Bone	Developmental and metabolic	Promote normal growth and skeletal development; accelerate bone turnover.
Nervous system	Developmental	Promote normal brain development.
Gut	Metabolic	Increase rate of carbohydrate absorption.
Lipoprotein	Metabolic	Stimulate formation of LDL receptors.
Other	Calorigenic	Stimulate oxygen consumption by metabolically active tissues (exceptions: adult brain, testes, uterus, lymph nodes, spleen, anterior pituitary). Increase metabolic rate.

Appendix: Thyroid Hormone Structure-Activity Relationships

The synthesis and biologic evaluation of a wide variety of T₄ and T₃ analogs allowed a significant correlation of structural features with their relative importance in the production of hormonal responses. In general, only compounds with the appropriately substituted phenyl-X-phenyl nucleus have shown significant thyroid hormonal activities. Both single ring compounds such as DIT and a variety of its aliphatic and alicyclic ether derivatives showed no T₄-like activity in the rat antigoiter test, the method most often used in determining thyromimetic activity in vivo. Structure-activity relationships are discussed in terms of single structural variations of T₄ in the (1) alanine side chain, (2) 3- and 5-positions of the inner ring, (3) the bridging atom, (4) 3'- and 5'-positions of the outer ring, and (5) the 4-phenolic hydroxyl group.

Aliphatic Side Chain. The naturally occurring hormones are biosynthesized from L-tyrosine and possess the L-alanine side chain. The L-isomers of T₄ and T₃ are more active than the D-isomers. The carboxylate ion and the number of atoms connecting it to the ring are more important for activity than is the intact zwitterionic alanine side chain. In the carboxylate series, the activity is maximum with the two-carbon acetic acid side chain but decreases with either the shorter formic acid or the longer propionic and butyric acid analogs. Ethylamine side chain analogs of T₄ and T₃ are less active than the corresponding carboxylic acid analogs. In addition, isomers of T₃ in which the alanine side chain is transposed with the 3-iodine or occupies the 2-position were inactive in the rat antigoiter test, indicating a critical location for the side chain in the 1-position of the inner ring.

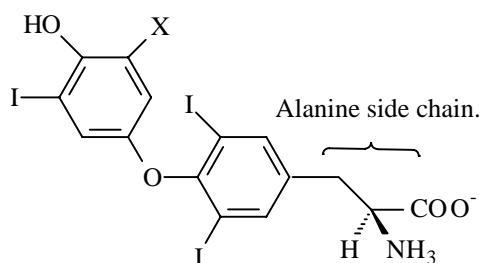

L-Enantiomers (S)

Alanine Bearing Ring. The phenyl ring bearing the alanine side chain, called the inner ring or A-ring, is substituted with iodine in the 3 and 5 positions in T₄ and T₃. Removal of both iodine atoms from the inner ring to form 3',5'-T₂ or 3'-T₁ produces analogs devoid of T₄-like activity primarily owing to the loss of the diphenyl ether conformation. Retention of activity observed on replacement of the 3 and 5 iodine atoms with bromine implies that iodine does not play a unique role in thyroid hormone activity. Moreover, a broad range of hormone activity found with halogen free analogs indicating that a halogen atom is not essential for activity. In contrast to T₃, 3'-isopropyl-3,6-dimethyl-l-thyronine has the capacity to cross the placental membrane and exerts thyromimetic effects in the fetus after administration to the mother. This could prove useful in treating fetal thyroid hormone deficiencies or in stimulating lung development (by stimulating lung to synthesize special phospholipids [surfactant], which ensure sufficient functioning of the infant's lungs at birth) immediately before premature birth. Substitution in the 3- and 5-positions by alkyl groups significantly larger and less symmetric than methyl groups, such as isopropyl and secondary butyl moieties, produces inactive analogs. These results show that 3,5-disubstitution

by symmetric, lipophilic groups, not exceeding the size of iodine, is required for activity.

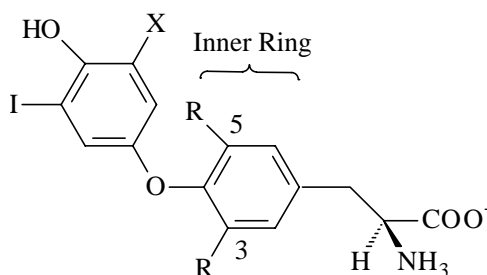

Bridging Atom. Several analogs have been synthesized in which the ether oxygen bridge has been removed or replaced by other atoms. The biphenyl analog of thyroxine, formed by removal of the oxygen bridge, is inactive in the rat antigoiter test. The linear biphenyl structure is a drastic change from the normal diphenyl ether conformation found in the naturally occurring hormones. Replacement of the bridging oxygen atom by sulfur ($Y=S$) or by a methylene group ($Y=CH_2$) produces highly active analogs. This provides evidence against the Niemann quinoid theory, which postulates that the ability of a compound to form a quinoid structure in the phenolic ring is essential for thyromimetic activity, and emphasizes the importance of the three-dimensional structure and receptor fit of the hormones. Attempts to prepare amino and carbonyl-bridged analogs ($Y=CO$) of T_3 and T_4 have been unsuccessful.

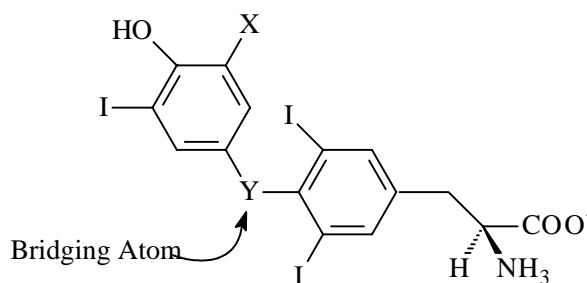

Phenolic Ring. The phenolic ring, also called the outer or beta-ring, of the thyronine nucleus is required for hormonal activity. Variations in 3' or 3',5' substituents on the phenolic ring have dramatic effects on biologic activity and the affinity for the nuclear receptor. The unsubstituted parent structure of this series L-T2 possesses low activity. Substitution at 3'-position by polar hydroxyl or nitro groups causes decrease in activity as a consequence of both lowered lipophilicity and intramolecular hydrogen bonding with the 4'-hydroxyl. Conversely, substitution by nonpolar halogen or alkyl groups results in an increase in activity in direct relation to bulk and lipophilicity of the substituent, e.g., $F < Cl < Br < I$ and $CH_3 < CH_2CH_3 < CH(CH_3)_2$. Although 3'-isopropylthyronine is the most potent analog known, being about 1.4 times as active as L- T_3 , n-propylthyronine is only about one-fourth as active as isopropyl, apparently because of its less compact structure. As the series is further ascended, activity decreases with a further reduction for the more bulky 3'-phenyl substituent. Substitution in both 3'- and 5'-positions by the same halogen produces less active hormones than the corresponding 3'-monosubstituted analogs. The decrease in activity has been explained as due to the increase in phenolic hydroxyl ionization and the resulting increase in binding to TBG (the primary carrier of thyroid hormones in human plasma). In general, a second substituent adjacent to the phenolic hydroxyl (5'-position) reduces

activity in direct proportion to its size.

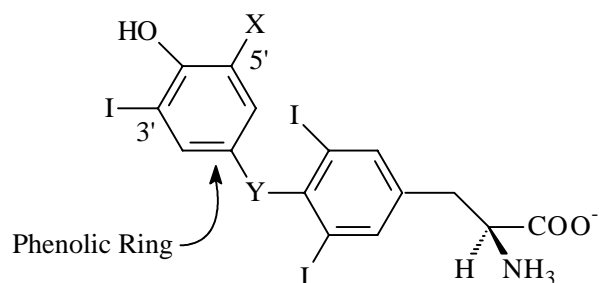

Phenolic Hydroxyl Group. A weakly ionized phenolic hydroxyl group at the 4-position is essential for optimum hormonal activity. Replacement of the 4-hydroxyl with an amino group ($Y=NH_2$) results in a substantial decrease in activity, presumably as a result of the weak hydrogen bonding ability of the latter group. The retention of activity observed with the 4'-unsubstituted compound ($Y=H$) provides direct evidence for metabolic 4'-hydroxylation as an activating step. Introduction of a 4'-substituent that cannot mimic the functional role of a hydroxyl group, such as a methyl group ($Y=CH_3$), and that is not metabolically converted into a functional residue results in complete loss of hormonal activity. The thyromimetic activity of the 4-methyl ether ($Y=OCH_3$) was ascribed to the ready metabolic cleavage to form an active 4-hydroxyl analog. The pKa of 4'-phenolic hydroxyl group for T_4 is 6.7 (90 percent ionized at pH 7.4) and for T_3 is 8.5 (approximately 10 percent ionized). The greater acidity for T_4 is reflective of its stronger affinity for plasma proteins and consequently its longer plasma half-life.

