

# **AUBURN UNIVERSITY**

## **RADIATION SAFETY**

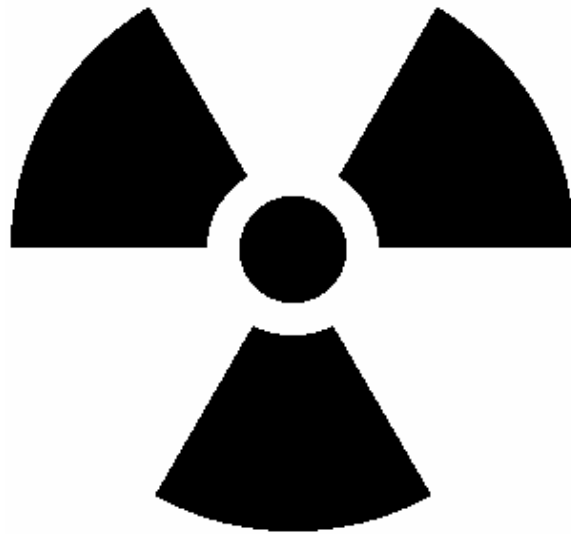

## **REFERENCE HANDBOOK**

**2006 Edition**

**AUBURN UNIVERSITY  
RISK MANAGEMENT AND SAFETY  
316 LEACH SCIENCE CENTER  
AUBURN UNIVERSITY, AL 36849  
(334) 844-4870**

## TABLE OF CONTENTS

Section 1.	INTRODUCTION .....	3
Section 2.	RADIATION FUNDAMENTALS.....	5
Section 3.	INTERACTION OF RADIATION WITH MATTER .....	9
Section 4.	ACTIVITY, EXPOSURE, AND DOSE.....	12
Section 5.	BIOLOGICAL EFFECTS OF IONIZING RADIATION .....	17
Section 6.	RADIATION DOSIMETRY PROGRAM .....	20
Section 7.	RADIOACTIVE MATERIAL HANDLING AND LABORATORY SAFETY .....	22
Section 8.	RADIATION SURVEY METERS.....	33
Section 9.	RADIOACTIVE WASTE DISPOSAL .....	36
Section 10.	RADIATION SAFETY FOR ANALYTICAL X-RAY UNITS .....	38
Appendix A	DOSE CONCEPTS.....	41
Appendix B	RADIATION RULES OF THUMB .....	45
Appendix C	EXCERPT FROM US NRC REGULATORY GUIDE 8.29 – INSTRUCTION CONCERNING RISKS FROM OCCUPATIONAL RADIATION EXPOSURE .....	46
Appendix D	EXCERPT FROM US NRC REGULATORY GUIDE 8.13 – INSTRUCTION CONCERNING PRENATAL RADIATION EXPOSURE .....	60
Appendix E	SI UNITS AND CONVERSION FACTORS.....	71
Appendix F	GLOSSARY OF TERMS.....	75
Appendix G	REFERENCES .....	79

## Section 1. INTRODUCTION

### RADIOLOGICAL SAFETY MANUAL

This handbook is a companion to the *Radiation Safety Manual (RSM)*. The RSM describes the radiation protection program at Auburn University. The policies and procedures contained in the RSM have been approved by the Radiation Safety Committee (RSC), and submitted to the Alabama Department of Public Health as part of our Radioactive Materials Licenses.

### RADIOLOGICAL SAFETY REFERENCE HANDBOOK

This *Radiation Safety Reference Handbook (RSRH)* presents the information necessary for individuals using radioactive materials and radiation-producing machines (radiation workers) to properly understand and follow the policies and procedures in the RSM. Some of the topics covered are:

- The nature of radiation and its interaction with matter.
- Definitions of units and terms used to describe radiation and radioactive material.
- Methods of calculating and measuring radiation levels for a variety of sources.
- The biological effects of ionizing radiation.
- Additional information on some of the policies and procedures in the RSM (e.g. dosimetry, waste disposal, and radionuclide handling).
- Safety precautions for the use of radiation-producing machines.

Some topics, such as particle accelerators and diagnostic x-ray machines, which are covered in other venues and applicable to a narrow group of Auburn personnel, are not covered in this handbook.

### ORIENTATION AND TRAINING

Each new radiation worker will attend an orientation at the Radiation Safety Office. This is usually a one-on-one meeting and the topics covered depend on the experience and knowledge of the new worker.

Those without extensive prior experience must complete a quiz on the material presented in the RSM, RSRH, and the orientation.

The Radiation Safety Officer may wave the orientation requirement for students taking an academic course where similar topics are presented (e.g. veterinary radiology course).

Training for each radiation worker is also provided in the laboratory by the Principal Investigator (PI) or an experienced worker designated by the PI. Topics covered during this training include, as appropriate:

- Safe use of laboratory equipment and materials, including protective clothing.

- Experiment procedures and protocols, including operating procedures for radiation-producing machines.
- Safe handling, storage, and disposal of radioactive materials.
- Methods to control and measure radiation levels and contamination.
- Proper maintenance of required records.
- Emergency procedures.

## **RADIOLOGICAL SAFETY OFFICE**

Radiation Safety personnel in Risk Management and Safety are available for consultation and to answer questions on the safe use of radioactive materials and radiation-producing machines. Radiation Safety also will keep Principal Investigators informed of changes in government regulations or university policies.

## Section 2. RADIATION FUNDAMENTALS

### INTRODUCTION

For the purposes of this manual, we can use a simplistic model of an atom. The atom can be thought of as a system containing a positively charged nucleus and negatively charged electrons which are in orbit around the nucleus.

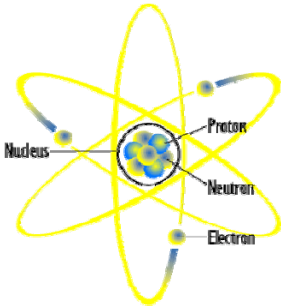

The nucleus is the central core of the atom and is composed of two types of particles, protons which are positively charged and neutrons which have a neutral charge. Each of these particles has a mass of approximately one atomic mass unit (amu). ( $1 \text{ amu} \approx 1.66 \times 10^{-24} \text{ g}$ ).

Electrons surround the nucleus in orbitals of various energies. (In simple terms, the farther an electron is from the nucleus, the less energy is required to free it from the atom.) Electrons are very light compared to protons and neutrons. Each electron has a mass of approximately  $5.5 \times 10^{-4}$  amu.

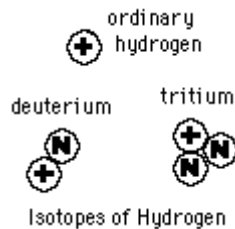
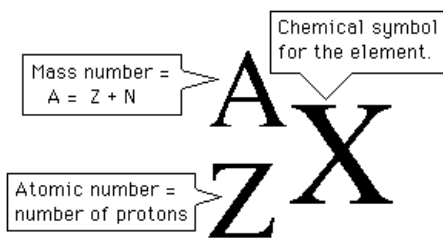

A *nuclide* is an atom described by its *atomic number* ( $Z$ ) and its *mass number* ( $A$ ). The  $Z$  number is equal to the charge (number of protons) in the nucleus, which is a characteristic of the element. The  $A$  number is equal to the total number of protons and neutrons in the nucleus. Nuclides with the same number of protons but with different numbers of neutrons are called *isotopes*. For example, deuterium ( ${}^2_1\text{H}$ ) and tritium ( ${}^3_1\text{H}$ ) are isotopes of hydrogen with mass numbers two and three, respectively. There are about 400 stable nuclides and over 1100 unstable (radioactive) nuclides. However, only about 10 or 15 radioactive nuclides are routinely used in research. Nuclides are radioactive primarily because of the number of neutrons in the nucleus, they have either an excess or deficiency of neutrons in the nucleus.

### RADIOACTIVE DECAY

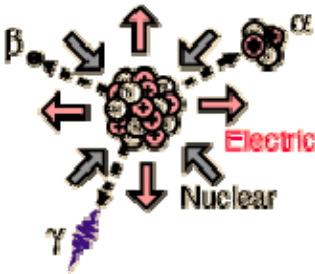

Radioactive nuclides (also called *radionuclides*) can regain stability by nuclear transformation (*radioactive decay*) emitting radiation in the process. The radiation emitted can be particulate or electromagnetic or both. The various types of radiation and examples of decay are shown below.

## ALPHA ( $\alpha$ )



Alpha particle

Alpha particles have a mass and charge equal to those of helium nuclei (2 protons + 2 neutrons). Alpha particles are emitted from the nucleus during the decay of some very heavy nuclides ( $Z > 83$ ).

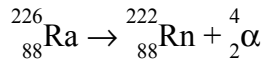

## BETA ( $\beta^-$ , $\beta^+$ )



Beta particles are emitted from the nucleus and have a mass equal to that of electrons. Betas can have either a negative charge or a positive charge. Negatively charged betas are equivalent to electrons and are emitted during the decay of neutron rich nuclides.

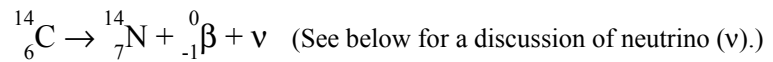

Positively charged betas (positrons,  $\beta^+$ ) are emitted during the decay of proton rich (neutron deficient) nuclides.

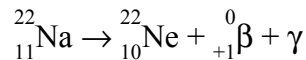

## GAMMA ( $\gamma$ )



Gammas (also called gamma rays) are electromagnetic radiation (photons) that are emitted from an excited ( $Y^*$ ) or metastable nucleus which resulted when other modes of decay (e.g.,  $\alpha$ ,  $\beta^-$ ,  $\beta^+$ ) failed to remove all the excess energy. The gamma is then emitted as an energy level transition within the nucleus. An “excited” nucleus usually emits the gamma within  $10^{-12}$  seconds of the particle emission.

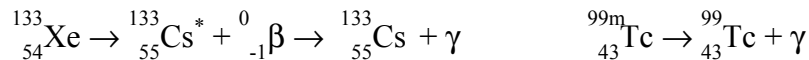

## ELECTRON CAPTURE ( $\epsilon$ or EC)

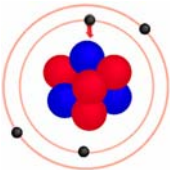

In certain neutron deficient nuclides, the nucleus will “capture” an orbital electron resulting in conversion of a proton into a neutron. This type of decay may also involve gamma emission as well as characteristic x-ray emission as other electrons fall into the orbital vacated by the captured electrons.

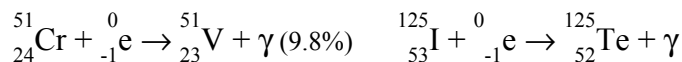

## FISSION

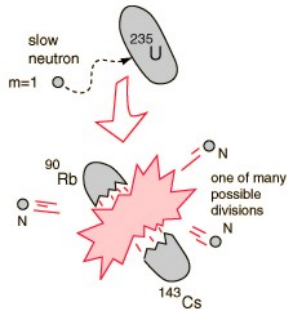

Fission is the splitting of an atomic nucleus into two smaller nuclei and usually two or three neutrons. This process also releases a large amount of energy in the form of gammas and kinetic energy of the fission fragments and neutrons. Fission is possible for a few very heavy naturally occurring radionuclides (e.g.,  $^{235}_{92}\text{U}$ ,  $^{238}_{92}\text{U}$ , etc.).

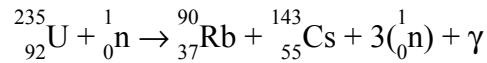

## NEUTRONS

For a few radionuclides, a neutron can be emitted during the decay process.

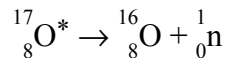

## X-RAYS



*Characteristic* x-rays are electromagnetic radiation (i.e., photons) emitted during energy level transitions of orbital electrons (cf., electron capture).

*Bremsstrahlung* x-rays (braking radiation) are produced when energetic electrons or beta particles are decelerated when passing close to a nucleus. This reaction predominates for high energy electrons/betas and heavy (e.g., lead) nuclei.

Bremsstrahlung must be considered when designing shielding for large quantities of high energy beta emitters such as P-32 and S-90.

## CHARACTERISTICS OF RADIOACTIVE DECAY

In addition to the type of radiation emitted, the decay of a radionuclide can be described by the following characteristics.

### HALF-LIFE

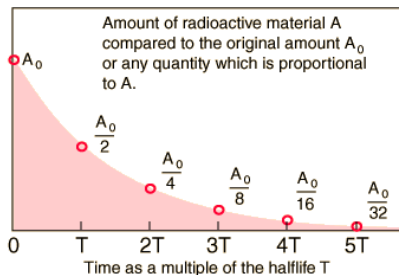

The half-life of a radionuclide is the time required for one-half of the radioactive atoms of that nuclide to decay.

Decay is a random process which follows an exponential curve. The number of radioactive nuclei remaining after time (t) is given by:

$$N_t = N_0 e^{-(0.693t/T)}$$

where  $N_0$  = original number of atoms  
 $N_t$  = number remaining at time  $t$   
 $t$  = decay time  
 $T$  = half-life

## ENERGY

The basic unit used to describe the energy of a radiated particle or photon is the electron volt (eV). An electron volt is equal to the amount of energy gained by an electron passing through a potential difference of one volt and  $1 \text{ eV} = 1.602 \times 10^{-19} \text{ J}$ .

The energy of the radiation emitted is a characteristic of the radionuclide. For example, the energy of the alpha emitted by Cm-238 will always be 6.52 MeV. The gamma emitted by Ba-135m will always be 268 keV.

Some radionuclides have more than one decay route. That is, there may be different possible energies that the radiation may have, but there are only a few possibilities for each radionuclide. For example, Na-22 decays by the emission of a positron ( $\beta^+$ ) 89.8% of the time and by electron capture (EC) 9.2% of the time.

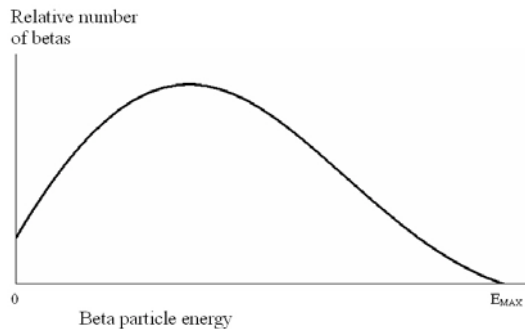

A characteristic of beta decay is that when a beta particle is emitted, the energy is divided between the beta particle and a neutrino. A neutrino is a particle with no charge and infinitesimally small mass. Consequently, a beta particle may be emitted with an energy varying in a continuous spectrum from zero to a maximum energy ( $E_{\text{max}}$ ) which is characteristic of the radionuclide. The average energy is generally around forty percent of the maximum.



## Section 3. INTERACTION OF RADIATION WITH MATTER

### ENERGY ABSORPTION

The transfer of energy from the emitted particle or photon to an absorbing medium has several mechanisms. These mechanisms result in ionization and excitation of atoms or molecules in the absorber. The transferred energy is eventually dissipated as heat.

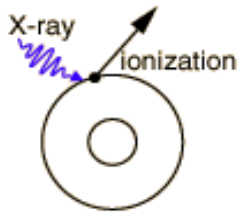

*Ionization* is the removal of an orbital electron from an atom or molecule, creating a positively charged ion. In order to cause an ionization, the radiation must transfer enough energy to the electron to overcome the binding force on the electron. The ejection of an electron from a molecule can cause dissociation of the molecule.



*Excitation* is the addition of energy to an orbital electron, thereby transferring the atom or molecule from the ground state to an excited state.

### ALPHA PARTICLES

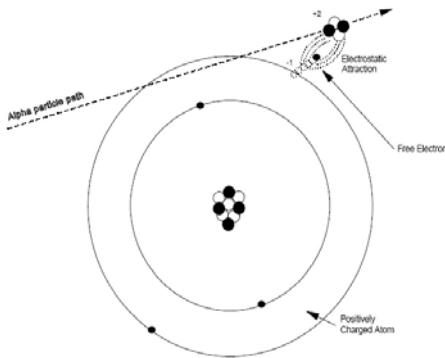

Interactions between the electric field of an alpha and orbital electrons in the absorber cause ionization and excitation events. Because of their double charge and low velocity (due to their large mass), alpha particles lose their energy over a relatively short range. One alpha will cause tens of thousands of ionizations per centimeter in air. The range in air of the most energetic alpha particles commonly encountered is about 10 centimeters (4 inches). In denser materials, the range is much less. Alpha particles are easily stopped by a sheet of paper or the protective (dead) layers of skin.

### BETA PARTICLES

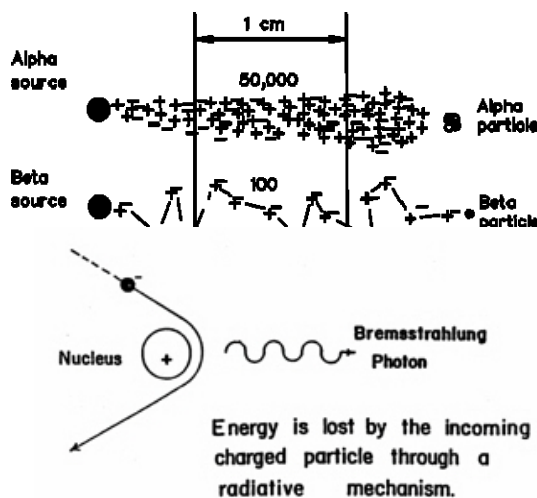

Normally, a beta particle loses its energy in a large number of ionization and excitation events. Due to the smaller mass, higher velocity and single charge of the beta particle, the range of a beta is considerably greater than that of an alpha of comparable energy. The maximum ranges of beta particles in air and tissue as well as Plexiglas is shown in Table 3.1. Since the beta particle mass is equal to that of an electron, a large deflection can occur with each interaction, resulting in many path changes in an absorbing medium.

If a beta particle passes close to a nucleus, it decreases in velocity due to interaction with the



positive charge of the nucleus, emitting x-rays (bremsstrahlung). The energy of the bremsstrahlung x-rays has a continuous spectrum up to a maximum equal to the maximum kinetic energy of the betas. The production of bremsstrahlung increases with the atomic number of the absorber and the energy of the beta. Therefore, low  $Z$  materials (e.g., Plexiglas) are used as beta shields.

A positron will lose its kinetic energy through ionizations and excitations in a similar fashion to a negative beta particle. However, the positron will then combine with an electron. The two particles are annihilated, producing two 511 keV photons called annihilation radiation.

## PHOTONS

Gammas and x-rays differ only in their origin. Both are electromagnetic radiation, and differ only from radio waves and visible light in having much shorter wavelengths. They have zero rest mass and travel with the speed of light. They are basically distortions in the electromagnetic field of space, and interact electrically with atoms even though they have no net electrical charge. There are three mechanisms by which gammas and x-rays lose energy.

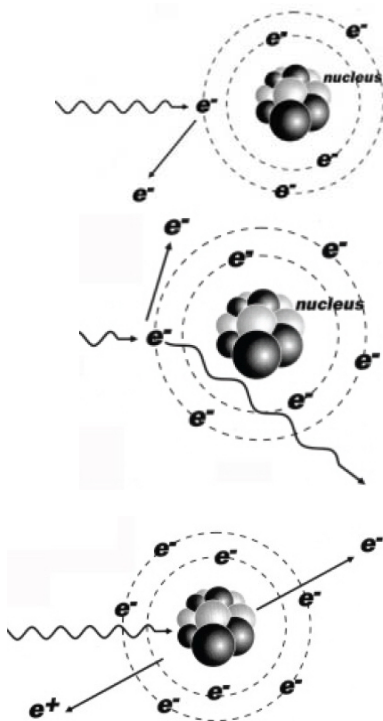

The *photoelectric effect* is one in which the photon imparts all its energy to an orbital electron. The photon simply vanishes, and the absorbing atom becomes ionized as an electron (photoelectron) is ejected. This effect has the highest probability with low energy photons ( $< 50$  keV) and high  $Z$  absorbers.

*Compton scattering* provides a means for partial absorption of photon energy by interaction with a "free" (loosely bound) electron. The electron is ejected, and the photon continues on to lose more energy in other interactions. In this mechanism of interaction, the photons in a beam are scattered, so that radiation may appear around corners and in front of shields.

*Pair production* occurs only when the photon energy exceeds 1.02 MeV. In pair production the photon simply disappears in the electric field of a nucleus, and in its place two electrons, a negatron and a positron, are produced from the energy of the photon. The positron will eventually encounter a free electron in the absorbing medium. The two particles annihilate each other and their mass is converted into energy. Two photons are produced each of 0.511 MeV. The ultimate fate of these two photons is energy loss by Compton scattering or the photoelectric effect.

While alpha- and beta-particles have a finite maximum range and can therefore be completely stopped with a sufficient thickness of absorber, photons interact in a probabilistic manner. This means that an individual photon has no definite maximum range. However, the total fraction of photons passing through an absorber decreases exponentially with the thickness of the absorber.

Table 3.1. Range / Penetration of  $\beta$  Particles and  $\gamma$ -ray Shielding Considerations

Isotope	Symbol	Decay	Exposure (mR/hr) <sup>†</sup>	$\beta$ Particle Range (cm / in)		Thickness (mm) <sup>‡</sup>	
				in Air	in Tissue	Lead	Plexiglas
Hydrogen-3 <sup>***</sup>	<sup>3</sup> H	$^{-}\beta$	--	0.5 cm / 0.25"	0.0005 cm / 0.0003"	--	0.1 <sup>***</sup>
Carbon-14 <sup>***</sup>	<sup>14</sup> C	$^{-}\beta$	--	25.4 cm / 10"	0.03 cm / 0.012"	--	0.3 <sup>***</sup>
Sodium-22	<sup>22</sup> Na	$^{+}\beta, \gamma$	13.3	--	--	27.9	1.6 <sup>**</sup>
Phosphorus-32	<sup>32</sup> P	$^{-}\beta$	353 <sup>*</sup>	610 cm / 240"	0.76 cm / 0.35"	--	7
Phosphorus-33 <sup>***</sup>	<sup>33</sup> P	$^{-}\beta$	--	51 cm / 20"	0.06 cm / 0.025"	--	0.5 <sup>***</sup>
Sulfur-35 <sup>***</sup>	<sup>35</sup> S	$^{-}\beta$	--	26 cm / 10.5"	0.04 cm / 0.015"	--	0.3 <sup>***</sup>
Calcium-45 <sup>***</sup>	<sup>45</sup> Ca	$^{-}\beta$	--	51 cm / 20"	51 cm / 20"	--	0.5 <sup>***</sup>
Chromium-51	<sup>51</sup> Cr	$\gamma$	0.18	--	--	5.6	--
Zinc-65	<sup>65</sup> Zn	$\epsilon, \gamma$	3.0	--	--	33.2	--
Rubidium-86	<sup>86</sup> Rb	$^{-}\beta, \gamma$	0.56	--	--	32.5	7 <sup>**</sup>
Technetium-99m	<sup>99m</sup> Tc	$\gamma$	0.8	--	--	1.0	--
Iodine-125	<sup>125</sup> I	$\epsilon, \gamma$	0.78	--	--	0.056	--
Iodine-131	<sup>131</sup> I	$^{-}\beta, \gamma$	2.4	--	--	9.7	1.2 <sup>**</sup>

<sup>†</sup>Unshielded exposure rate (mR/hr) 30 cm (12 inch) from 37 MBq (1.0 mCi) source

<sup>‡</sup>Lead to reduce  $\gamma$  exposure rate by factor of 10 (two TVL reduce exposure by a factor of 100) or Lucite to stop all  $\beta$

<sup>\*</sup>Radiation from pure beta emitting radionuclides is technically not measured in mR/hr and should not be shielded with lead; shield beta-particles with Lucite/Plexiglas

<sup>\*\*</sup>If gamma is attenuated by a factor of 10, dose rate from Bremsstrahlung x-rays should also be low

<sup>\*\*\*</sup>There is no need to shield low-energy  $\beta$ -particles <sup>3</sup>H, <sup>14</sup>C, <sup>33</sup>P, <sup>35</sup>S, <sup>45</sup>Ca

## SECONDARY IONIZATIONS

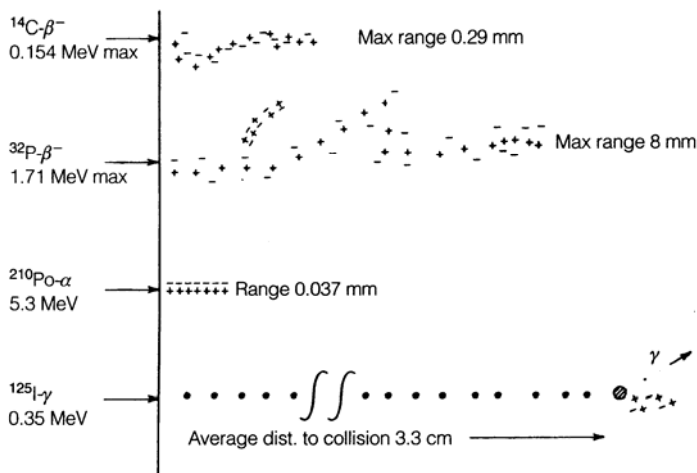

On average, it requires 34 eV (i.e., 25 – 45 eV) to produce each ion pair. A Po-210  $\alpha$ -particle with 5.3 MeV of energy will produce approximately 156,000 ion pairs. A P-32  $\beta$ -particle with 1.71 MeV (max) of energy will produce approximately 50,000 ion pairs. Some of the electrons from these ionizations are given sufficient kinetic energy to be capable of producing additional ionization and excitation events in the same way as described for beta particles. These energetic secondary electrons are called delta ( $\delta$ ) rays.

## Section 4. ACTIVITY, EXPOSURE, AND DOSE

### DEFINITIONS

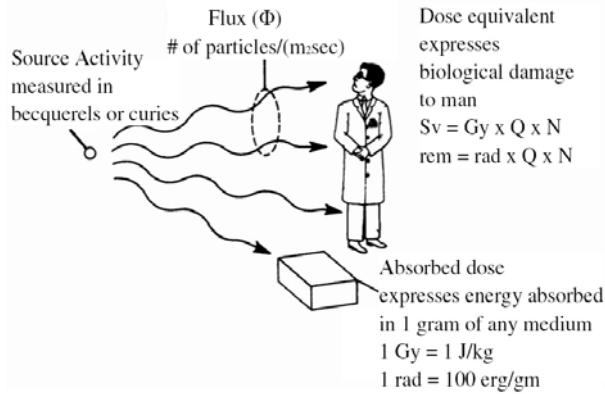

*Activity* is the rate of decay (disintegrations per unit time) of a given amount of radioactive material.

*Dose* is a measure of energy deposited by radiation in a material, or of the relative biological damage produced by that amount of energy given the nature of the radiation.

*Exposure* is a measure of the ionizations produced in air by x-ray or gamma radiation. The term exposure (with its "normal" definition) is sometimes used to mean dose. (e.g. "He received a radiation exposure to his hand.")

### UNITS

#### ACTIVITY

1 *Curie (Ci)* =  $3.7 \times 10^{10}$  disintegrations per sec (dps).

The *Becquerel (Bq)* has replaced the Curie in the *International System of Units (SI)* as a measure of activity where  $1 Bq = 1 dps$ ,  $3.7 \times 10^{10} Bq = 1 Ci$ , and  $1 mCi = 37 MBq$ .

#### EXPOSURE

The unit of radiation exposure in air is the *roentgen (R)*. It is defined as that quantity of gamma or x-radiation causing ionization in air equal to  $2.58 \times 10^{-4}$  coulombs per kilogram. Exposure applies only to absorption of gammas and x-rays with energies less than 3 MeV in air. The roentgen is not defined in the SI system of units. The SI unit of exposure is the *X unit*, defined as the production of 1 C of charge in 1 kg of air (i.e.,  $X = 1 C/kg$  air). Because the X unit is equivalent to 3876 R, a very large exposure, most exposure measurements are reported in roentgen (R).

#### ABSORBED DOSE

The *rad* is a unit of absorbed dose. One rad is equal to an absorbed dose of 100 ergs/gram. ( $1 erg = 6.24 \times 10^{11} eV$ ) The SI unit of absorbed dose is the *Gray (Gy)*.  $1 Gy = 1 joule/kilogram = 100 rad$ . Historically, an exposure of 1 R results in an absorbed dose of 0.87 rad.

#### DOSE EQUIVALENT

Not all radiation produces the same amount of biological damage in workers. The *quality factor (Q)* is used to compare the biological effectiveness of various types of radiation, given equal amounts absorbed dose (rad). The effectiveness of radiation in producing damage is related to the energy loss of the radiation per unit path length, often expressed as the *linear energy transfer (LET)*. Generally, the greater the LET in tissue, the more effective the radiation is in producing damage. The quality factors for radiations frequently encountered are:

<u>Radiation</u>	<u>Q</u>
Gammas and x-rays	1
Beta particles & electrons	1
Alpha particles & fission fragments	20
Neutrons	10

The *rem* is the unit of dose equivalent. The dose equivalent in rem is equal to the absorbed dose in rad multiplied by the quality factor (i.e.,  $\text{rem} = Q \times \text{rad}$ ). Dose equivalent determinations for internally deposited radioactive materials also take into account other factors such as the non-uniform distribution of some radionuclides (e.g. I-125 in the thyroid). The SI unit for dose equivalent is the Sievert (Sv) which is calculated the same as the rem (i.e.,  $\text{Sv} = Q \times \text{Gy}$ ).  $1 \text{ Sv} = 100 \text{ rem}$ .

## CALCULATION OF ACTIVITIES

The half-life of a radionuclide is the time required for one-half of a collection of atoms of that nuclide to decay. This is the same as saying it is the time required for the activity of a sample to be reduced to one-half the original activity. The half-life equation in Section 2 can be rewritten as:

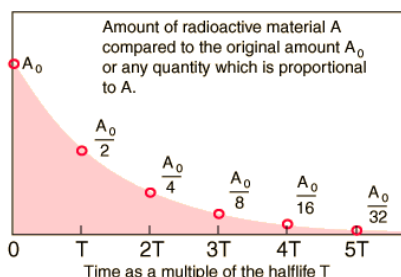

$$A_t = A_0 e^{-(0.693t/T)}$$

where  $A_0$  = original activity  
 $A_t$  = activity at time  $t$   
 $t$  = decay time  
 $T$  = half-life

### EXAMPLE

P-32 has a half-life of 14.3 days. On January 10, the activity of a P-32 sample was 10  $\mu\text{Ci}$ . What will the activity be on February 6?

February 6 is 27 days after January 10 so

$$A_{2/6} = A_{1/10} e^{-[0.693(27/14.3)]} = 2.7 \mu\text{Ci}$$

A quick estimate could also have been made by noting that 27 days is about two half-lives (28.6 days). So the new activity would be about one-half of one-half (i.e. one-fourth) of the original activity.

## CALCULATION OF EXPOSURE RATES

Gamma exposure constants ( $\Gamma$ ) for many radionuclides are given in Table 4.2.  $\Gamma$  is the exposure rate in R/hr at 1 cm from a 1 mCi point source.

An empirical rule rule-of-thumb which may also be used is the 6CEn rule. This states that exposure rate in R/h at one foot in air from C curies of a radionuclide that emits n photons of energy E (MeV), where  $0.07 < E < 4$ , per disintegration is:

$$6 \times \text{Ci} \times E \times n = \text{R/hr @ 1 foot,}$$

where Ci = source strength in curies

E = energy of the emitted photons in MeV

n = fraction of decays resulting in photons with an energy of E

It should be noted that this formula and the gamma constants are for exposure rates from gammas and x-rays only. Any dose calculations would also have to include the contribution from any particulate radiation that may be emitted.

### INVERSE SQUARE LAW

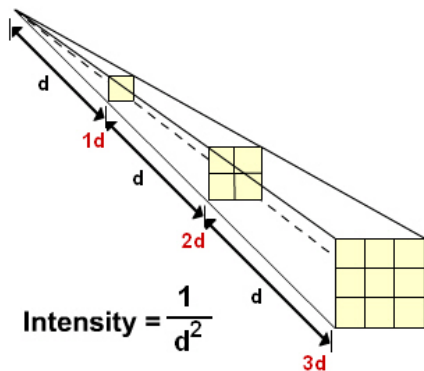

Exposure rate varies inversely with the square of the distance from a point source of radiation. This is often referred to as the inverse square law (or  $1/r^2$  rule).

$$\text{ER}_2 = \text{ER}_1 \times (d_1/d_2)^2$$

where  $\text{ER}_2$  = exposure rate at distance 2

$\text{ER}_1$  = exposure rate at distance 1

$d_1$  = distance 1

$d_2$  = distance 2

For example, from Table 4.2, the  $\Gamma$  for Co-60 is 13.2 R/hr @ 1 cm per mCi. Therefore, the exposure rate at 1 cm from a 1 mCi source would be 13.2 R/hr. At 30 cm from the same source, the exposure rate would be  $(13.2 \text{ R/hr})(1/30)^2 = 0.0147 \text{ R/hr} = 14.7 \text{ mR/hr}$ .

### BETA DOSE RATES

For a beta emitter point source, the dose rate in air can be calculated using the empirical equation:

$$300 \times \text{Ci} = \text{rad/hr @ 1 foot, where Ci = source strength in curies.}$$

This calculation neglects any shielding provided by the air, which can be significant. For example, the maximum range in air for a beta from S-35 is less than one foot (see Table 3.1), so the dose rate at one foot is zero for any size S-35 source.

Because beta particles are emitted in a spectrum of energies and the low energy beta particles are rapidly attenuated, they do not follow the inverse square law. Table 4.1 provides an approximation of the beta dose rate versus distance.

Table 4.1. Beta dose rate (rad/hr) from a 37 MBq (1 mCi) point source

Radionuclide	Energy (MeV)	Distance (cm)							
		0	0.2	0.5	10	10	30	50	100
$^{14}\text{C} / ^{35}\text{S}$	~0.160	2035.7	241.7	21.3	1.78	0.04	--	--	--
$^{33}\text{P} / ^{45}\text{Ca}$	~0.250	1532.3	219.0	26.6	4.23	0.40	0.05	--	--
$^{32}\text{P} / ^{86}\text{Rb}$	1.710	350.0	87.0	13.8	3.44	0.87	0.39	0.14	0.03

## SKIN DOSE

Because nearly all of the energy from beta particles with energies below 0.6 MeV (e.g., H-3, C-14, P-33, S-35, Ca-45) is deposited within the dead layer of the skin, there is essentially zero skin dose from these radionuclides. For energies above 0.6 MeV, a practical estimate of the dose rate to the skin from a uniform deposition of 1  $\mu\text{Ci}/\text{cm}^2$  of a beta emitter on the skin is about 9 rad/hr. Empirically, the skin dose rate from P-32 is 6 rad/hr per  $\mu\text{Ci}$  or 0.1622 rad/hr per kBq.

## INTERNAL DOSE CALCULATIONS

See Appendix A for methods and examples of internal dose calculations.

Table 4.2. Gamma exposure constants ( $\Gamma$ )

Nuclide	$\Gamma$	Nuclide	$\Gamma$	Nuclide	$\Gamma$
Actinium-227	2.2	Gold-198	2.3	Potassium-43	5.6
Antimony-122	2.4	Gold-199	0.9	Radium-226	8.25
Antimony-124	9.8	Hafnium-175	2.1	Radium-228	5.1
Antimony-125	2.7	Hafnium-181	3.1	Rhenium-186	0.2
Arsenic-72	10.1	Indium-114m	0.2	Rubidium-86	0.5
Arsenic-74	4.4	Iodine-124	7.2	Ruthenium-106	1.7
Arsenic-76	2.4	Iodine-125	1.5	Scandium-46	10.9
Barium-131	3.0	Iodine-126	2.5	Scandium-47	0.56
Barium-133	2.4	Iodine-130	12.2	Selenium-75	2.0
Barium-140	12.4	Iodine-131	2.2	Silver-110m	14.3
Beryllium-7	0.3	Iodine-132	11.8	Silver-111	0.2
Bromine-82	14.6	Iridium-192	4.8	Sodium-22	12.0
Cadmium-115m	0.2	Iridium-194	1.5	Sodium-24	18.4
Calcium-47	5.7	Iron-59	6.4	Strontium-85	3.0
Carbon-11	5.9	Krypton-85	0.04	Tantalum-182	6.8
Cerium-141	0.35	Lanthanum-140	11.3	Tellurium-121	3.3
Cerium-144	0.4	Lutecium-177	0.09	Tellurium-132	2.2
Cesium-134	8.7	Magnesium-28	15.7	Thulium-170	0.025
Cesium-137	3.3	Manganese-52	18.6	Tin-113	1.7
Chlorine-38	8.8	Manganese-54	4.7	Tungsten-185	0.5
Chromium-51	0.16	Manganese-56	8.3	Tungsten-187	3.0
Colbalt-56	17.6	Mercury-197	0.4	Uranium-234	0.1
Colbalt-57	0.9	Mercury-203	1.3	Vanadium-48	15.6
Colbalt-58	5.5	Molybdenum-99	1.8	Xenon-133	0.1
Colbalt-60	13.2	Neodymium-147	0.8	Ytterbium-88	0.4
Colbalt-64	1.2	Nickel-65	3.1	Yttrium-88	14.1
Europium-152	5.8	Niobium-95	4.2	Yttrium-91	0.01
Europium-154	6.2	Osmium-191	0.6	Zinc-65	2.7
Europium-155	0.3	Palladium-109	0.03	Zirconium-95	4.1
Gallium-67	1.1	Platinum-197	0.5		
Gallium-72	11.6	Potassium-42	1.4		

$\Gamma$  = exposure rate in R/hr at 1 cm from a 1 mCi point source

$\Gamma/10$  = exposure rate in mR/hr at 1 meter from a 1 mCi point source



## Section 5. BIOLOGICAL EFFECTS OF IONIZING RADIATION

### RADIATION HAZARDS

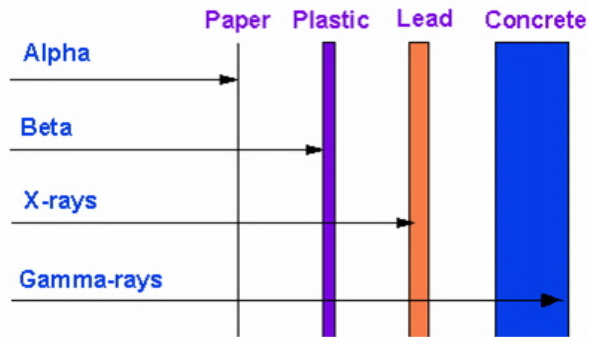

The hazards associated with the absorption of radiation in mammalian systems and tissue are related to both the type of radiation and the nature of the absorbing tissue or organ system.

#### ALPHA

Alpha particles will be stopped by the dead layers of skin, so they are not an external hazard. However, many alpha emitters or their daughters also emit gammas which are penetrating and therefore may present an external hazard. Internally, alphas can be very damaging due to their high linear energy transfer (LET). That is, they deposit all of their energy in a very small area. Based on their chemical properties, alpha emitters can be concentrated in specific tissues or organs.

#### BETA

Externally, beta particles can deliver a dose to the skin or the tissues of the eye. Many beta emitters also emit gammas. A large activity of a high energy beta emitter can create a significant exposure from bremsstrahlung x-rays produced in shielding material. Internally, betas can be more damaging, especially when concentrated in specific tissues or organs.

#### PHOTONS

Externally, the hazard from low energy (< 30 keV) gammas and x-rays is primarily to the skin or the tissues of the eye. Higher energies are more penetrating and therefore a whole body hazard. Internally, gamma emitters can effect not only the tissues or organs in which they are deposited, but also surrounding tissues.

### EFFECTS OF RADIATION

As discussed earlier, radiation causes atoms and molecules to become ionized or excited. These ionizations and excitations can result in:

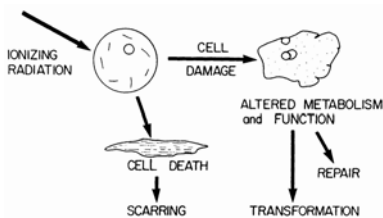

- Production of free radicals.
- Breakage of chemical bonds.
- Production of new chemical bonds and cross-linkage between macromolecules.
- Damage to molecules which regulate vital cell processes (e.g. DNA, RNA, proteins).

## TISSUE SENSITIVITY

In general, the radiation sensitivity of a tissue varies directly with the rate of proliferation of its cells and inversely with the degree of differentiation. Table 5.1 gives an indication of various sensitivities.

Table 5.1. Radiosensitivity of Normal Cells

Very High	High	Intermediate	Low
Lymphocytes	Urinary bladder epithelium	Endothelium	Mature hematopoietic cells
Immature hematopoietic cells	Esophageal epithelium	Growing bone fibroblasts	Muscle cells
Intestinal epithelium	Gastric mucosa	Glandular epithelium of breast	Mature connective tissues
Spermatogonia	Mucous membranes	Pulmonary epithelium	Mature bone and cartilage
Ovarian follicular cells	Epidermal epithelium	Renal epithelium	Ganglion cells
	Optic lens Epithelium	Thyroid epithelium	

## EFFECTS OF ACUTE HIGH RADIATION DOSES

A whole body radiation dose of greater than 25 to 50 rem received in a short time results in the clinical "acute radiation syndrome." This syndrome, which is dose related, can result in disruption of the functions of the bone marrow system (>25 rem), the gastrointestinal system (>500 rem), and the central nervous system (>2000 rem). An acute dose over 300 rem can be lethal.

## EFFECTS OF LOW RADIATION DOSES

There is no disease uniquely associated with low radiation doses.

Immediate (i.e., acute) effects are not seen below doses of 25 rem. Latent effects may appear years after a dose is received. The effect of greatest concern is the development of some form of cancer.

The National Academy of Sciences Committee on Biological Effects of Ionizing Radiation (BEIR) issued a report in 1990 entitled "Health Effects of Exposure to Low Levels of Ionizing Radiation," also known as BEIR V. The following is an excerpt from the Executive Summary of the report:

On the basis of the available evidence, the population-weighted average lifetime risk of death from cancer following an acute dose equivalent to all body organs of 0.1 Sv (0.1 Gy of low-LET radiation) is estimated to be 0.8%, although the lifetime risk varies considerably with age at the time of exposure. For low LET radiation, accumulation of the same dose over weeks or months, however, is expected to reduce the lifetime risk appreciably, possibly by a factor of 2 or more. The Committee's estimated risks for males and females are similar. The risk from exposure during childhood is estimated to be about twice as large as the risk for adults, but such estimates of lifetime risk are still highly uncertain due to the limited follow-up of this age group. ....

The Committee examined in some detail the sources of uncertainty in its risk estimates and concluded that uncertainties due to chance sampling variation in the available epidemiological data are large and more important than potential biases such as those due to differences between various exposed ethnic groups. Due to sampling variation alone,

the 90% confidence limits for the Committee's preferred risk models, of increased cancer mortality due to an acute whole body dose of 0.1 Sv to 100,000 males of all ages range from about 500 to 1200 (mean 760); for 100,000 females of all ages, from about 600 to 1200 (mean 810). This increase in lifetime risk is about 4% of the current baseline risk of death due to cancer in the United States. The Committee also estimated lifetime risks with a number of other plausible linear models which were consistent with the mortality data. The estimated lifetime risks projected by these models were within the range of uncertainty given above. The committee recognizes that its risk estimates become more uncertain when applied to very low doses. Departures from a linear model at low doses, however, could either increase or decrease the risk per unit dose.

If an Auburn University worker were to receive 10% of the maximum allowable dose each year for twenty years, the total dose received would be 10 rem (0.1 Sv). According to the BEIR V report, the worker's chance of death from cancer would increase by approximately 0.4%. This is fairly small compared to the normal chance of death from cancer in the U. S. of about 20%.

## Section 6. RADIATION DOSIMETRY PROGRAM

### EXTERNAL DOSIMETRY

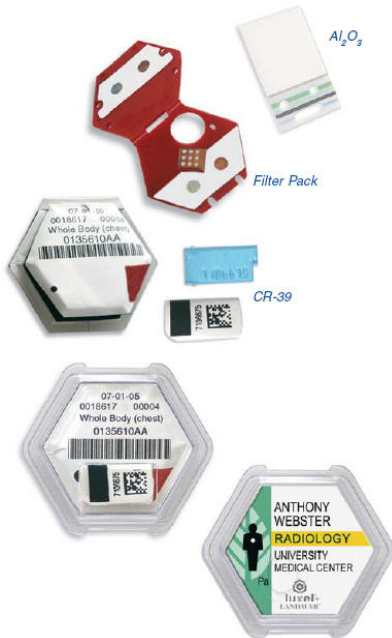

Auburn University currently uses optically stimulated luminescence (OSL) dosimeters and thermoluminescent dosimeters (TLDs) supplied and processed by an independent outside company. Other types of dosimeters such as film badges may also be used.

#### OSL BADGE

An OSL dosimeter is used in place of the film badge and has similar detection capabilities. The detection method is similar to a TLD, but instead of heating it, the dosimeter is read using laser stimulation.

#### FILM BADGE

The film badge is used to measure whole body dose and shallow dose. It consists of a film packet and a holder. The film is similar to ordinary photographic film but will be exposed by radiation. (It will also be exposed by light, so if the packet is opened or damaged, the reading will be invalid.) The holder has several filters which help in determining the type and energy of radiation. The badge will detect gamma and x-rays, high energy beta particles, and in certain special cases, neutrons. It does not register radiation from low energy beta emitters such as  $^3H$ ,  $^{14}C$ , and  $^{35}S$ , since their betas will not penetrate the paper covering on the film packet.

The badge is usually worn at the collar or chest level to measure the radiation dose received by the trunk of the body. When not in use, the badge should be left in a safe place on campus away from any radiation sources. (Use the film badge rack if one is provided.) Be sure the badge is available for the film packet exchange which is done quarterly.



#### TLD RING

The TLD ring is used to measure dose to the hand. They are issued to individuals who may use multiple millicurie amounts of a gamma or high energy beta emitter. The TLD is a small crystal which absorbs the energy from radiation. When heated, it releases the stored energy in the form of visible light. The crystal is mounted in a ring which should be worn on the hand which is expected to receive the larger dose. Wear the ring inside your glove with the label facing towards your palm.

## OTHER

Individuals working with certain materials or machines may be issued additional or specialized dosimetry.

## PRECAUTIONS

The radiation doses recorded by your dosimeters become part of your occupational radiation dose record. Make sure that this record is valid and accurate by observing the following precautions:

- Always wear your badge when using radioactive materials or radiation-producing machines. Wear your ring when using gamma or high energy beta emitters.
- Keep your dosimeters away from radiation sources when not in use. Do not deliberately expose a dosimeter to radiation or wear your badge when receiving medical or dental x-rays.
- Do not tamper with the dosimeter packet or remove it from the holder.
- Never wear someone else's dosimeter or let someone else wear yours.
- Avoid subjecting the badge to high temperatures or getting it wet.

Notify Risk Management and Safety if your badge or ring has been damaged or lost, or if you have reason to believe that you or your dosimeter has received an accidental high dose.

## STATE NOTIFICATION

Auburn University is required by law to report to the Alabama Department of Public Health (ADPH) any personnel dosimeter which shows a dose higher than the occupational dose limits. It is a violation of Alabama regulations and the conditions of our Radioactive Material Licenses to deliberately expose a personnel dosimeter to a radiation source (except when being used as intended). The dose recorded by the dosimeter will become part of the dose record of the individual to whom it was issued unless it can be proven to ADPH that the individual did not actually receive the dose.

## **INTERNAL DOSIMETRY**

Auburn University's licenses require that individuals using certain amounts unsealed radionuclides be included in a bioassay program. Whether or not a bioassay (usually urinalysis or thyroid assay) is required depends on the nuclide, form, and activity of the radioactive material being used.

## Section 7. RADIOACTIVE MATERIAL HANDLING AND LABORATORY SAFETY

### REDUCTION OF DOSE TO PERSONNEL

The following are ways in which radiation doses can be reduced.

#### TIME

Because it is assumed that radiation damage is cumulative, the total dose you receive is linearly proportional to your radiation risk. Carefully plan your activities in order to minimize the length of time spent handling or in the vicinity of radiation sources. Practice unfamiliar procedures to reduce the time needed to perform them.

#### DISTANCE

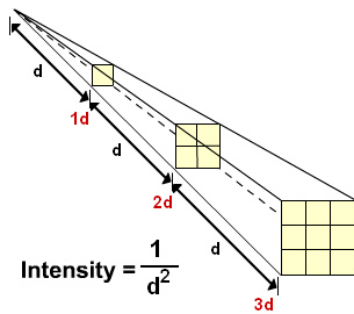

Increasing the distance from a radiation source by the use of handling devices will reduce the dose received, since exposure rate decreases as  $1/r^2$ , where  $r$  is the distance from a point source. For example:

At 10 cm, a 5 mCi I-125 source has an exposure rate of 75 mR/hr. Moving to 30cm would reduce the exposure rate to

$$(75 \text{ mR/hr})(10/30)^2 = 8.3 \text{ mR/hr}$$

Note: The  $1/r^2$  formula (also known as the inverse square law) does not take into account shielding provided by air. This can be significant for alpha and beta radiation. Even the most energetic alpha particles have a range in air of only about 4 inches. A beta from the decay of C-14 or S-35 has a maximum range in air of about 12 inches.

If you are not directly working with radioactive material, stay about 6 feet (2 meters) away. From the inverse square law, the exposure at 6 feet will be about 2.7% of the exposure at 1 foot (i.e., an exposure of 100 mR at 1 foot will only be 2.7 mR at 6 feet).

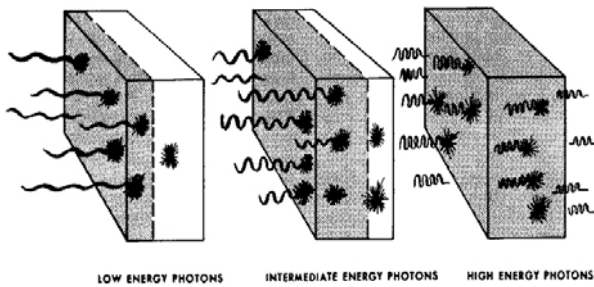

#### SHIELDING

As gammas and x-rays pass through an absorber their decrease in number (by the processes discussed in Section 3) is governed by the energy of the radiation, the density of the absorber medium, and the thickness of the absorber. This can be expressed approximately as:

$$I = I_0 e^{-\mu x}$$

where  $I_0$  is the intensity (number of photons per unit area) of the initial radiation,  
 $I$  is the radiation intensity after it has passed through the absorber,  
 $\mu$  is a factor called the linear absorption coefficient. (The value of  $\mu$  depends on the energy of the incident radiation and the density of the absorbing medium.), and  
 $x$  is the thickness of the absorber.

## TVL & HVL

The thicknesses of an absorber needed to reduce the radiation intensity by a factor of two and by a factor of ten are called the *half-value layer (HVL)* and the *tenth-value layer (TVL)*, respectively. Approximate lead TVL's, HVL's and linear attenuation coefficients for some radionuclides are listed below (see also Table 3.1).

Nuclide	$\gamma$ Energy (MeV)	HVL (mm)	TVL (mm)	$\mu$ (cm <sup>-1</sup> )
I-125	0.035	0.05	0.16	150
Am-241	0.060	0.14	0.45	51
Co-57	0.122	2.0	6.7	3.4
Cs-137	0.662	6.5	21	1.1
Na-22	1.28	9.6	32	0.72
Co-60	1.17 & 1.33	12	40	0.58

### EXAMPLE

At 30 cm, a 10 mCi Co-60 source produces an exposure rate of about 150 mR/hr. How much lead shielding is needed to reduce the rate to 4 mR/hr?

From the table, see that for Co-60, one TLV of lead, 40 mm, will reduce the rate by a factor of 10, from 150 mR/hr to 15 mR/hr. Adding 12 mm (one HVL) of lead will make it 7.5 mR/hr. One more HVL will reduce the rate to about 4 mR/hr. So the total lead shielding needed is  $40 + 12 + 12 = 64$  mm.

## SHIELDING CONCERNS

When designing shielding there are several points to be kept in mind.

- Persons outside the shadow cast by the shield are not necessarily protected.
- A wall or partition may not be a safe shield for people on the other side.
- Radiation can be "scattered" around corners.

### BREMSSTRAHLUNG

The absorption of high energy beta radiation (e.g. <sup>32</sup>P and <sup>90</sup>Sr) in high Z materials such as lead and tungsten may result in the production of electromagnetic radiation (bremsstrahlung) which is more penetrating than the beta radiation that produced it. Low Z materials such as plastics and glass minimize the production of bremsstrahlung.

## HANDLING PRECAUTIONS

Here are some of the radiological characteristics of and special precautions associated with some radionuclides commonly used on campus. In addition to the specific precautions for each nuclide, the following general precautions should always be followed when applicable to your work.

- Whenever practical, designate specific areas for radioactive material handling and use. Clearly label the area and all containers. Minimize and confine contamination by using absorbent paper and spill trays. Handle potentially volatile materials in certified fume hoods.
- Do not smoke, eat, or drink in rooms where radioactive materials are used. Do not store food or drink in refrigerators, freezers, or cold rooms used for radioactive material storage.
- Use an appropriate instrument to detect radioactive contamination. Regularly monitor the work area. Always monitor yourself, the work area, and equipment for contamination when your experiment or operation is completed. Decontaminate when necessary.
- Use appropriate shielding when handling millicurie or greater amounts of gamma emitters or high energy beta emitters. Remember that waste containers may also need shielding.
- Wear the dosimeters issued to you while using radioactive materials.
- Wash your hands before leaving the lab, using a telephone, or handling food.



### H-3 (TRITIUM) INFORMATION

Radioactive half-life	12.4 years
Decay mechanism	Beta emission
Energy	$E_{\max} = 18.6 \text{ keV}$
Contamination monitoring	Liquid scintillation counter for wipe surveys
Dosimetry	Urinalysis

1. Because the beta emitted has a very low energy, tritium can not be detected with the usual survey meters found in the lab. Therefore, special care is needed to keep the work area from becoming contaminated. Tritium can be detected by doing a wipe survey and counting the wipes in a liquid scintillation counter.
2. Many tritiated compounds readily penetrate gloves and skin. Wearing two pairs of gloves and changing the outer pair every fifteen or twenty minutes will reduce the chances of cross contamination and absorption through the skin.
3. Tritium bound to amino acids, DNA, RNA and their precursors will be metabolized differently than tritiated water. It is estimated that the dose from tritiated thymidine may be 8 – 10 times more damaging than from tritiated water.

## C-14 INFORMATION

Radioactive half-life	5730 years
Decay mechanism	Beta emission
Energy	$E_{\max} = 0.156 \text{ MeV}$
Contamination monitoring	Thin window Geiger-Mueller detector, liquid scintillation counter for wipe surveys
Dosimetry	None needed

1. Some C-14 labeled compounds can penetrate gloves and skin. Wearing two pairs of gloves and changing the outer pair every fifteen or twenty minutes will reduce the chances of absorption through the skin.
2. C-14 may be difficult to distinguish from S-35. If both nuclides are being used in the same laboratory, establish controls to ensure they are kept separate. If "unknown" contamination is found, treat it as C-14.

## P-32 INFORMATION

Radioactive half-life	14.3 days
Decay mechanism	Beta emission
Energy	$E_{\max} = 1.709 \text{ MeV}$
Contamination monitoring	thin window Geiger-Mueller detector
Shielding	1 cm Lucite / Plexiglas
Dosimetry	Whole body badge, TLD ring

P-32 Decay Table

days	0	1	2	3	4	5	6
0	1000	953	908	865	824	785	748
7	712	679	646	616	587	559	533
14	507	483	460	439	418	398	379
21	361	344	328	312	298	284	270
28	257	245	234	223	212	202	192
35	183	175	166	159	151	144	137
42	131	124	119	113	108	102	98
49	93	89	84	80	77	73	70
56	66	63	60	57	55	52	50

1. The dose rate on contact on the side of a 1 mCi delivery vial can be on the order of 1000 mrem/hr. If possible, avoid direct hand contact with vials and sources. When working with 100  $\mu\text{Ci}$  or more of P-32, work should be done behind a 1 cm lucite shield.
2. One microcurie of P-32 in direct contact with 1  $\text{cm}^2$  of bare skin gives a dose rate to the skin of about 9 rem/hr. Always protect your skin and eyes when handling unsealed materials. Wear gloves, lab coats, safety glasses, and shoes.
3. A thin window G-M survey meter should always be available. A survey should be made immediately after use and any "hot spots" should be decontaminated.
4. A whole body dosimeter must be worn for all P-32 work. If you have been issued a TLD ring, it should be worn whenever working with P-32.
5. Handle and store your radioactive waste carefully. The polyethylene bottles for liquid waste should be placed in a secondary container (e.g. a bucket or tray) to contain spills or leaks. When more than a millicurie is involved, place 1 cm thick lucite in front of the waste container for shielding.

## P-33 INFORMATION

Radioactive half-life	25.3 days
Decay mechanism	Beta emission
Energy	$E_{\max} = 0.249 \text{ MeV}$
Contamination monitoring	Thin window Geiger-Mueller detector, liquid scintillation counter for wipe surveys
Dosimetry	None needed

P-33 Decay Table

days	0	1	2	3	4	5	6
0	1000	973	947	921	897	872	849
7	826	804	782	761	741	721	701
14	683	664	646	629	612	595	579
21	564	549	534	520	506	492	479
28	466	453	441	429	418	406	395
35	385	374	364	355	345	336	327
42	318	309	301	293	285	277	270
49	263	256	249	242	236	229	223

1. P-33 can be used in any P-32 protocol. Because it is lower in energy (i.e., 0.249 MeV) than P-32, no shielding is required.
2. P-33 range in tissue is only 0.6 mm. Dosimeters are not issued for P-33 work and the beta particle will not penetrate a double layer of disposable gloves.
3. Counting efficiency should be higher than the efficiency for S-35 / C-14. While not as easy to detect with a GM as P-32, it is still relatively easy to detect if survey meters are used properly.

## S-35 INFORMATION

Radioactive half-life	87.4 days
Decay mechanism	Beta emission
Energy	$E_{\max} = 0.167 \text{ MeV}$
Contamination monitoring	Thin window Geiger-Mueller detector, liquid scintillation counter for wipe surveys
Dosimetry	Urinalysis

S-35 Decay Table

days	0	1	2	3	4	5	6
0	1000	992	984	976	969	961	954
7	946	939	931	924	916	909	902
14	895	888	881	874	867	860	853
21	847	840	833	827	820	814	807
28	801	795	788	782	776	770	764
35	758	752	746	740	734	728	722
42	717	711	705	700	694	689	683
49	678	673	667	662	657	652	646
56	641	636	631	626	621	616	612

1. Radiolysis of S-35 labeled amino acids may lead to the release of S-35 labeled volatile impurities. Delivery vials should therefore be opened in a fume hood.
2. The addition of stabilizers (buffers) will reduce, but not eliminate, the evolution of S-35 volatiles from tissue culture media and procedures which involve heating and thawing. Incubators and water baths should be checked for contamination after using S-35 methionine or other volatile compounds.
3. S-35 may be difficult to distinguish from C-14. If both nuclides are being used in the same laboratory, establish controls to ensure they are used in separate areas. If "unknown" contamination is found, treat it as C-14.

<b>Ca-45 INFORMATION</b>
--------------------------

Radioactive half-life	163 days
Decay mechanism	Beta emission
Energy	$E_{\max} = 0.257$ MeV
Contamination monitoring	Thin window Geiger-Mueller detector, liquid scintillation counter for wipe surveys
Dosimetry	None needed

Ca-45 Decay Table (5-day interval)

days	0	5	10	15	20	25	30
0	1000	979	959	939	919	900	881
35	863	844	827	810	793	776	760
70	744	728	713	698	684	669	655
105	642	628	615	602	590	577	565
140	553	542	531	519	509	498	488
175	477	467	458	448	439	430	421
210	412	403	395	386	378	370	363
245	355	348	340	333	326	320	313

1. Ca-45 is a bone seeker with a long residence time (i.e., effective half-life is 162.7 days). Work with quantities in excess of 1 mCi will require special precautions and survey procedures.
2. Ca-45 is radiologically similar to P-33. It can be readily detected with a thin-window GM and LSC counter.

<b>I-125 INFORMATION</b>
--------------------------

Radioactive half-life	59.6 days
Decay mechanism	Electron capture (gamma and x-ray emission)
Energy	27-35 keV
Contamination monitoring	Thin crystal NaI detector, liquid scintillation counter for wipe surveys
Shielding	Thin lead
Dosimetry	Film badge, TLD ring, thyroid scan

I-125 Decay Table

days	0	1	2	3	4	5	6
0	1000	988	977	966	955	944	933
7	922	911	901	890	880	870	860
14	850	840	830	821	811	802	792
21	783	774	765	756	748	739	731
28	722	714	705	697	689	681	673
35	666	658	650	643	635	628	621
42	614	606	599	593	586	579	572
49	566	559	553	546	540	534	527
56	521	515	509	504	498	492	486

The following precautions are applicable to iodination procedures or the handling of radioiodine in activities higher than typically found in RIA kits.

1. The dose rate at 1 cm from a 1 mCi point source is about 1.5 rem/hr. The dose rate is inversely related to the square of the distance from the source. Thus while a small amount of I-125 held for a short time can result in a significant dose to the hands, a relatively short separation distance reduces the dose rate to an acceptable level.
2. The volatility of iodine requires special handling techniques to minimize radiation doses. Solutions containing iodide ions (such as NaI) should not be made acidic or be frozen. Both lead to formation of volatile elemental iodine. Once bound to a protein, the volatility of the radioiodine is tremendously reduced.
3. Always work in a fume hood with a minimum face velocity of at least 100 linear feet per minute when working with NaI. The sash should be below the breathing zone.
4. Use shoulder length veterinary gloves with short vinyl gloves on top to minimize skin absorption.
5. Avoid opening the septum on delivery vials. It is preferable to remove radioiodine using a hypodermic needle and syringe.

6. A radiation survey instrument should be available in the immediate area. A low energy scintillation detector is preferable to a G-M detector. You should do a wipe survey in your work areas after each use.
7. Film badges must be worn for all radioiodine work. If you have been issued a TLD ring, it should be worn whenever working with I-125.
8. Use lead to shield quantities of 1 mCi or more. 1 mm of lead will essentially block all of the radiation emitted from I-125.
9. Until waste is picked up by Radiological Safety, it should be kept in the waste containers supplied by Radiological Safety and stored in a fume hood.



## Section 8. RADIATION SURVEY METERS

### INTRODUCTION

There are several types of portable radiation survey instruments in use on campus. Various types have different qualities and can therefore have very different detection capabilities.

As a user of radioactive materials or radiation-producing machines, you are expected to be able to use the survey meters in your laboratory. During your initial training, you will learn how to operate the instruments in your lab. You should know their capabilities and limitations and be able to interpret the meter readings.

### GEIGER-MUELLER DETECTOR

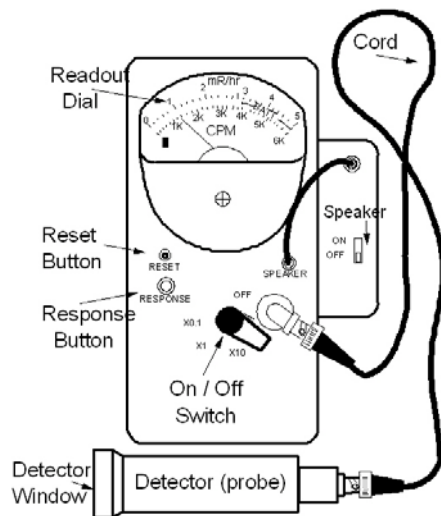

The Geiger-Mueller (G-M) counter is the most common radiation detection instrument on campus. In this type of meter, an ionization in the detector results in a large output pulse that causes meter and audio responses. Because of the inherent characteristics of the detector, all initial ionizing events produce the same size output pulse. Therefore, the meter does not differentiate among types or energies of radiation.

Most G-M detectors have a thin mica film "window" at one end. This window is very fragile. Always use the thin end window for detecting pure beta emitters and low energy photons (e.g.  $^{32}\text{P}$ ,  $^{35}\text{S}$ ,  $^{14}\text{C}$ ,  $^{55}\text{Fe}$ ,  $^{125}\text{I}$ , and x-rays less than 40 keV). The aluminum side wall should be used only for the detection of penetrating x-rays and gamma radiation.

Table 8.1. Effect of Cling Film on Efficiency

Isotope	$E_{\text{max}}$ (MeV)	Percent Efficiency		
		Unshielded	Cling Film	Parafilm M
$^{14}\text{C}/^{35}\text{S}$	$\approx 0.160$	4.05	2.52	0.13
$^{33}\text{P}/^{45}\text{Ca}$	$\approx 0.250$	8.90	7.48	2.12
$^{32}\text{P}$	1.710	22.4	22.0	21.5

your GM to protect against contamination. *Covering the window with plastic wrap or paraffin film will stop most or all of their betas from entering the detector.* Table 8.1 shows that cling film produces a 50% decrease in efficiency for C-14 / S-35 and Parafilm M stops all C-14 / S-35 beta particles from entering. The effect, especially for Parafilm M, is not quite as dramatic for P-33 / Ca-45. High-energy beta particles from P-32 are relatively unaffected.

Very low energy beta emitters such as  $^3\text{H}$  and  $^{63}\text{Ni}$  are not detectable because these beta particles do not have enough energy to penetrate the window. They are best detected by using liquid scintillation counting techniques.  $^{14}\text{C}$  and  $^{35}\text{S}$  emit betas energetic enough to pass through the thin window. Do not cover the window of

The *efficiency* of a meter for a specific source of radiation is given by the ratio of the meter count rate to the actual disintegration rate of the source, that is:

$$\text{actual decay rate} = \text{meter reading} / \text{efficiency}$$

Some examples of approximate G-M efficiencies through the end window at 1 cm (~ 1/2 inch) from a point source are given below:

$^3\text{H}$	$\beta$ , 0.018 MeV	not detectable
$^{14}\text{C}$ , $^{35}\text{S}$	$\beta$ , 0.160 MeV	5 % - 10 %
$^{33}\text{P}$ , $^{45}\text{Ca}$	$\beta$ , 0.250 MeV	10 % - 20 %
$^{32}\text{P}$	$\beta$ , 1.710 MeV	30 % - 45 %
$^{125}\text{I}$	$\gamma$ , 0.030 MeV	0.01% - 0.03%

There are many factors affecting efficiency. These include distance (e.g., inverse square effects), detector geometry (e.g., end-window versus pancake), detector age, etc. The numbers listed should serve as a guide to relate radiation energy with detector efficiency. You should use your meter to indicate the presence of contamination, then clean contaminated areas exceeding limits in Appendix C of the Radiation Safety Manual.

#### EXAMPLE

Your G-M counter reads 5000 cpm at one inch from a small spot of P-32 contamination on the bench. What is the total activity of the contamination (assume a 25% efficiency)?

$$\begin{aligned} \text{actual disintegration rate} &= (5000 \text{ cpm}) / (0.25 \text{ cpm/dpm}) \\ &= 20,000 \text{ dpm} = 333 \text{ dps} \\ &= 333 \text{ Bq} = 9 \text{ nCi} \end{aligned}$$

Because of the randomness of radioactive decay, the meter reading at low count rates often fluctuates widely. For this reason, the audio speaker is sometimes a better indicator of small amounts of radioactivity than the meter reading. At higher count rates, the speaker response is often faster than the meter reading. It is better, therefore, to have the speaker on when using a G-M counter.

Very high radiation fields may temporarily overload the detector circuit resulting in a partial or complete loss of meter or audio response. If this happens, remove the meter and yourself from the area and push the reset button or turn the meter off then back on. The meter should resume normal operation. Always turn on a survey meter before entering an area that might have high radiation fields.

## SCINTILLATION DETECTOR

Scintillation detectors which incorporate a sodium iodide crystal are used in some laboratories for the detection of low energy gamma emitters such as  $^{125}\text{I}$ . Some survey meters allow the use of either a G-M detector or a scintillation detector. The efficiency

of a low energy scintillation probe for the detection of  $^{125}\text{I}$  is about 25% at 1 cm (½ inch) – over a hundred times better than a G-M probe.

## ION CHAMBER

Ionization chambers are suitable for measuring radiation exposure rate or cumulative radiation exposure at high radiation intensities. They are not especially useful at low radiation intensities or for detecting small quantities of radioactive material.

## CALIBRATION



Most survey meters have scales that read in milliRoentgen per hour (mR/hr) and/or counts per minute (cpm) or counts per second (cps). After detector efficiency is taken into consideration, the cpm or cps scales give an indication of the quantity of radioactivity. The mR/hr scales give an indication of the radiation exposure rate. There is an important difference in these measurements. *Exposure rate measurements are only valid for electromagnetic (x- /  $\gamma$ ) radiation.*

Radiological Safety calibrates all of the portable radiation survey instruments on campus. One of two types of calibration procedures are used. One is for GM survey meters that are used for detection and measurement of particulate radiation. Another is for meters used for detection and measurement of x- and  $\gamma$  radiation. The two procedures are explained briefly below so that you will know what to expect.

Survey meters used in biology and chemistry research labs are calibrated for the detection and measurement of particulate radiation. These meters are calibrated using a pulse generator so that the cpm or cps scales read correctly (i.e., one pulse in = one meter count). If the meter also reads in mR/hr, those readings may not be accurate for the measurement of electromagnetic radiation (i.e., for  $\gamma$ -rays, approximately 2,000 – 4,000 cpm is 1 mR/hr).

Survey meters that are used for radiation exposure (i.e., mR/hr) measurements are calibrated with a comparable radiation source. The mR/hr scale will read correctly when the detector is exposed to electromagnetic radiation greater than 100 keV.

## Section 9. RADIOACTIVE WASTE DISPOSAL

### INTRODUCTION

Due to Federal legislation, out-of-state low-level radioactive waste (LLRW) disposal facilities are either no longer accepting Alabama generated LLRW or will stop in the near future. In response to this, Radiological Safety stores most radioactive waste generated at Auburn University. The purpose of this storage is to allow time for the decay of short-lived radionuclides and to facilitate the proper disposal of all radioactive waste.

### MIXED HAZARDOUS/RADIOACTIVE WASTE

Radioactive waste containing any hazardous chemicals requires special handling. Radiological Safety must be consulted before any such waste is generated.

### WASTE MINIMIZATION

Because all radioactive waste must be stored on campus until it decays or until it can be shipped to an authorized LLRW disposal facility, it is important that the amount of waste generated be kept to a minimum. Radiological Safety has a limited area to store radioactive waste. Some ways to minimize waste are:

- Design experiments to use as little radioactive material as possible.
- Use proper handling techniques. (See Section 7.) This will reduce the chance of contamination.
- When practical, use techniques which do not involve radioactive materials. There are many new techniques and products available which can be used in place of radioactive materials.
- Monitor for contamination and dispose of as little as possible. If there is a spot of contamination on a piece of absorbent paper, cut out that spot and dispose of it rather than the whole piece. Don't automatically place your gloves in the radioactive waste. Monitor them. If there is no detectable contamination, throw them in the normal (black-bag) waste container.
- Liquid radioactive waste includes the radioactive material and the first rinse of its experimental container. After the first rinse, the container can be washed in the sink.

## **SEGREGATION BY HALF-LIFE**

Radioactive waste should be segregated according to radionuclide half-life. The three categories for segregation are:

- Half-life less than 15 days (P-32)
- Half-life between 15 and 120 days (P-33, S-35, Ca-45, Cr-51, I-125)
- Half-life greater than 120 days (H-3, C-14, Ca-45)

Waste containers should be marked with the category of waste they are intended for. It is very important that waste is placed in the proper container.

If waste contains two different radionuclides, place it in the container appropriate for the longer half-life.

## **PROHIBITED ITEMS**

Solid waste can not be picked up by Radiological Safety if it contains any of the following:

- Hazardous material (e.g. lead [see below], toxins)
- Biohazard bags or other hazardous material markings – inactivate and overpack any formerly biohazardous waste.
- Radioactive markings (except in long half-life solid waste or burnable solid waste)
- Sharps (e.g. needles, razor blades) – double box sharps and present separately

Liquid radioactive waste must be readily soluble or dispersible in water. It must not contain any hazardous materials such as solvents.

## **LEAD PIGS/SHIELDING**

Lead shipping containers and other lead shielding should not be disposed of as ordinary trash or placed in solid radioactive waste containers. Lead which is boxed and identified will be picked up by Radiological Safety when requested.

## **DISPOSAL PROCEDURES**

Disposal procedures are described in the Radiological Safety Manual.

## Section 10. RADIATION SAFETY FOR ANALYTICAL X-RAY UNITS

### NATURE OF ANALYTICAL X-RAYS

Analytical x-ray machines produce intense beams of ionizing radiation that are used for diffraction and fluorescence studies. The most intense part of a beam is that corresponding to the  $K_{\alpha}$  emission of the x-ray tube target material and is called characteristic radiation. In addition to the characteristic radiation, a continuous radiation spectrum of low intensity is produced ranging from a very low energy to the maximum kV-peak setting. This is referred to as "bremsstrahlung" or white radiation. Undesirable wavelengths may be filtered out using a monochromator.

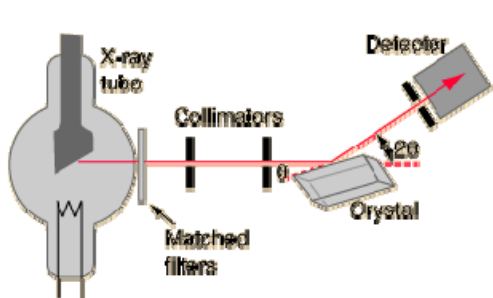

X-ray diffraction wavelengths ( $\lambda$ ) are selected so as to roughly correspond to the inter-atomic distances within the sample, and to minimize fluorescence. Wavelengths commonly used are 1.54 Å (Cu targets), 0.71 Å (Mo targets), 0.56 Å (Ag targets), and 2.3 Å (Cr targets). The relationship between wavelength and x-ray photon energy is determined by the equation

$$E = hc/\lambda$$

where  $E$  = energy in ergs ( $1 \text{ eV} = 1.6 \times 10^{-12} \text{ erg}$ )  
 $h$  = Planck's constant =  $6.614 \times 10^{-27} \text{ erg-sec}$   
 $c$  = velocity of light =  $3 \times 10^{10} \text{ cm/sec}$   
 $\lambda$  = wavelength in cm ( $1 \text{ Å} = 1 \times 10^{-8} \text{ cm}$ )

X-rays emitted from an open, uncollimated port form a cone of about 30°. The x-ray flux can produce a radiation field at one meter on the order of 10,000 R/hr. A collimator reduces the beam size to about 1 millimeter diameter.

### X-RAY HAZARDS AND BIOLOGICAL EFFECTS

X-rays produced by diffraction machines are readily absorbed in the first few millimeters of tissue and do not contribute any dose to the internal organs of the body. However, the lens of the eye can receive a dose from x-rays of this energy. Overexposure of lens tissue can lead to the development of lens opacities and cataracts.

Absorbed doses of a few hundred rad may produce a reddening of the skin (erythema) which is transitory in nature. Higher doses -- 10,000 rad and greater -- may produce significant cellular damage resulting in pigment changes and chronic radiation dermatitis. Exposure to erythema doses may not result in immediate skin reddening. The latent period may be from several hours to several days.

(Note: X-rays used for medical diagnosis are about one order of magnitude shorter in wavelength. Diagnostic rays are designed for tissue penetration and are carefully filtered to avoid x-ray damage to the skin caused by the longer, more readily absorbed wavelengths).

## SOURCES OF IONIZING RADIATION

The primary beam is not the only source of ionizing radiation. Any high voltage discharge is a potential source of x-rays. Faulty high-voltage vacuum-tube rectifiers may emit x-rays of twice the voltage applied to the x-ray tube. Other sources of ionizing radiation are:

- Secondary emissions and scattering from the sample, shielding material, and fluorescent screens.
- Leakage of primary or scattered x-rays through gaps and cracks in shielding.
- Penetration of the primary beam through or scattering from faulty shutters, beam traps, or collimator couplings.

## SAFETY PRECAUTIONS AND NOTES

The shielding, safety equipment and safety procedures prescribed for x-ray diffraction equipment are applicable only for up to 75 kV-peak x-rays. Additional or greater precautions are necessary for machines operating at higher voltages.

The Principal Investigator has the basic responsibility for providing a safe working environment by ensuring that equipment is operationally safe and that workers understand safety and operating procedures.

The equipment operator is responsible for his own safety and the safety of others when using an analytical x-ray machine.

Prior to removing shielding or working in the sample area, the operator must check both the warning lights and the current (mA) meter on the console. *Never trust a warning light unless it is on!* Always use a survey meter to check that the shutters are actually closed if current is still being supplied to the tube. It is possible for a shutter to be stuck partially open even when the indicator shows that it is shut. *The best way to avoid an accidental exposure is to turn the machine off before working in the sample area.*

Never put any part of the body in the primary beam. Exposure of any part of the body to the collimated beam for even a fraction of a second may result in damage to the exposed tissue.

A person not knowledgeable about x-ray equipment should not attempt to make repairs or remedy malfunctions. If you suspect a machine is malfunctioning, turn it off or unplug it. Place a note on the control panel and inform the PI or his designated representative.

Repairs to the high voltage section must not be made unless the primary leads are disconnected from the high voltage transformer and a signed and dated notice is posted near the x-ray ON switch. Turning off a circuit breaker is not sufficient.

Bare feet are not permitted in the laboratory or around electrical equipment. Even slightly moist skin is an excellent electrical conductor and contact with faulty, ungrounded equipment may result in severe injury or death.

Do not attempt to align x-ray cameras without first consulting an experienced person. Alignment procedures require special training and knowledge.

Special care is required when one power supply is connected to more than one x-ray tube.

### **TUBE STATUS INDICATORS**

There must be a visual indication located on or near the tube head to indicate when x-rays are being produced. This is usually an assembly consisting of two red bulbs, wired in parallel and labeled X-RAYS ON. If one of the lights is burned out, the operator should either replace it before leaving the room, or leave a note on the light assembly indicating that the bulb is burned out. An unlit warning bulb does not necessarily mean that x-rays are not being produced. Always check the control panel.

### **SAFETY DEVICES**

Interlock switches are used to prevent inadvertent access to the beam. They should not be bypassed. Interlocks should be checked periodically to insure that they are functioning properly.

*Interlocks and other safety devices and warning systems are not foolproof or fail-safe. A safety device should be used as a back-up to minimize the risk of radiation exposure – never as a substitute for proper procedures and good judgment.*



## Appendix A DOSE CONCEPTS

### INTRODUCTION

Changes to the federal radiation protection regulations took effect in January, 1994. These changes were based on reports and recommendations by the International Commission on Radiological Protection (ICRP), the National Council on Radiation Protection and Measurements (NCRP), and other organizations involved with radiation protection.

### TOTAL DOSE CONCEPT

Previously, the radiation doses received from external radiation sources and internally deposited radioactive materials were treated separately. Limits on internal uptake of radioactive materials were based on the dose to a "critical organ" and could not be compared to the "whole body" dose received from an external source.

The external dose number was and still is related to the risk of stochastic effects (primarily cancer). For a stochastic effect, the higher the dose received, the greater the chance of developing the effect. The new regulations have a mechanism for determining the increased risk of stochastic effects from an intake of radioactive material. The dose calculated is based on a variety of factors such as the biological half-life of the material, the distribution of the material in the body, and the type and energy of the radiation. The result is that both the external dose and the internal dose are related to the risk of stochastic effects and thus can be added to obtain a total dose.

### ORGAN DOSE

For a few radionuclides, the limits on intake are based on nonstochastic effects rather than stochastic effects. For a nonstochastic effect, the higher the dose received, the more severe the effect. However, unlike stochastic effects, there is a threshold dose, i.e. a certain dose, below which the effect will not occur. Limits on the internal intake of radioactive materials are set to keep organ doses well below the thresholds. Even in these cases, however, the additional risk of stochastic effects must also be determined.

The dose limit for external exposure of the lens of the eye is also based on prevention of a nonstochastic effect (lens opacities).

### DEFINITIONS

*Absorbed Dose* means the energy imparted by ionizing radiation per unit mass of irradiated material.

*Dose Equivalent* means the product of the absorbed dose in tissue, quality factor, and all other necessary modifying factors at the location of interest.

*Deep-dose Equivalent (DDE)*, which applies to external whole-body exposure, is the dose equivalent at a tissue depth of 1 cm.

*Shallow-dose Equivalent*, which applies to external exposure of the skin or an extremity, is the dose equivalent at a tissue depth of 0.007 cm.

*Eye Dose Equivalent*, which applies to the external exposure of the lens of the eye, is the dose equivalent at a tissue depth of 0.3 cm.

*Committed Dose Equivalent (CDE)* means the dose equivalent to organs or tissues of reference that will be received from an intake of radioactive material by an individual during the fifty-year period following the intake.

*Weighting Factor* for an organ or tissue is the proportion of the risk of stochastic effects when the whole body is irradiated uniformly.

*Committed Effective Dose Equivalent (CEDE)* is the sum of the products of the weighting factors applicable to each of the body organs or tissues that are irradiated and the CDE to these organs or tissues.

*Total Effective Dose Equivalent (TEDE)* means the sum of the deep-dose equivalent (for external exposures) and the committed effective dose equivalent (for internal exposures).  
 $TEDE = DDE + CEDE$

*Total Organ Dose Equivalent (TODE)* is the sum of the DDE and the CDE to an organ or tissue.

*Annual Limit on Intake (ALI)* means the derived limit for the amount of radioactive material taken into the body of an adult worker by inhalation or ingestion in a year. ALI is the smaller value of intake of a given radionuclide in a year by the reference man that would result in a CEDE of 5 rem or a CDE of 50 rem to any individual organ or tissue.

## EXAMPLE DOSE CALCULATIONS

Fortunately, the NRC has already determined the ALIs for all of the radionuclides and listed them in a table. This makes calculating CEDEs and CDEs fairly simple. Table 2 shows the ALIs for several of the radionuclides used at Auburn.

### EXAMPLE 1

P-32 in most chemical forms has an ALI for ingestion of 600  $\mu\text{Ci}$ . This is listed as a stochastic ALI, which means that ingesting 600  $\mu\text{Ci}$  of P-32 would result in a CEDE of 5 rem.

If a worker accidentally ingests 10  $\mu\text{Ci}$  of P-32, the CEDE would be  $(10 \mu\text{Ci})(5 \text{ rem}/600 \mu\text{Ci}) = 0.083 \text{ rem} = 83 \text{ mrem}$ .

## EXAMPLE 2

I-125 has a nonstochastic ALI for inhalation of 60  $\mu\text{Ci}$ . This means that inhaling 60  $\mu\text{Ci}$  of I-125 would result in a CDE to the thyroid of 50 rem. The stochastic ALI for inhalation of I-125 is 200  $\mu\text{Ci}$ .

If a worker accidentally inhales 3  $\mu\text{Ci}$  of I-125, the CDE to the thyroid would be  $(3 \mu\text{Ci})(50 \text{ rem}/60 \mu\text{Ci}) = 2.5 \text{ rem}$ . The CEDE would be  $(3 \mu\text{Ci})(5 \text{ rem}/200 \mu\text{Ci}) = 0.075 \text{ rem}$ .

Suppose this worker also received an external dose from working with a high energy gamma emitter. Evaluation of his film badge showed a DDE of 50 mrem. The TEDE would then be  $50 \text{ mrem} + 75 \text{ mrem} = 125 \text{ mrem}$ .

### EMBRYO/FETUS DOSE

The dose limit to the embryo/fetus of a declared pregnant woman is 0.5 rem. Efforts must also be made to avoid a dose substantially higher than 0.06 rem in one month. A declared pregnant woman means a woman who has voluntarily informed the Radiological Safety Office, in writing, of her pregnancy and the estimated date of conception.

The dose to an embryo/fetus is the sum of the deep-dose equivalent to the declared pregnant woman and the dose from internally deposited radionuclides in the embryo/fetus and in the woman.

### DOSE LIMITS

A summary of dose limits set by the revised regulations is shown in Table 1.

The dose limit for an individual member of the public is 0.1 rem/year TEDE.

Table 1  
Occupational Dose Limits

Dose Category	Adult Occupational Dose Limit
Total Effective Dose Equivalent (TEDE)	5 rem/year*
Total Organ Dose Equivalent (TODE)	50 rem/year to any individual organ or tissue except the lens of the eye*
Eye Dose Equivalent	15 rem/year*
Shallow Dose Equivalent	50 rem/year*
Embryo/Fetus Dose	0.5 rem for the entire gestation period

\*Occupational dose limit for minors is 10% of the adult limit

Table 2  
Annual Limit on Intake (ALI) for Radionuclides Commonly Used at Auburn

Radionuclide	Form	ALI for ingestion ( $\mu\text{Ci}$ )	ALI for inhalation ( $\mu\text{Ci}$ )
H-3	gas		$8 \times 10^8$
	other	$8 \times 10^4$	$8 \times 10^4$
C-14	most compounds	$2 \times 10^3$	$2 \times 10^3$
P-32	most compounds	$6 \times 10^2$	$9 \times 10^2$
P-33	most compounds	$6 \times 10^3$	$8 \times 10^3$
S-35	most compounds	$8 \times 10^3$ stochastic $1 \times 10^4$ nonstochastic	$2 \times 10^4$ stochastic
Ca-45	all compounds	$2 \times 10^3$	$8 \times 10^2$
Cr-51	most compounds	$4 \times 10^4$	$5 \times 10^4$
I-125	all compounds	$4 \times 10^1$ nonstochastic $1 \times 10^2$ stochastic	$6 \times 10^1$ nonstochastic $2 \times 10^2$ stochastic

## Appendix B RADIATION RULES OF THUMB

### ALPHA PARTICLES

An alpha energy of at least 7.5 MeV is required to penetrate the protective layer of the skin (0.07mm). All alpha emitters used at Auburn have less than 6.5 MeV of energy.

### BETA PARTICLES

A beta energy of at least 70 keV is required to penetrate the protective layer of the skin (0.07mm).

The average energy of a beta-spectrum is approximately one-third the maximum energy.

The range of beta particles in air is about 12 ft per MeV. (e.g. The maximum range of P-32 betas is  $1.71 \text{ MeV} \times 12 \text{ ft/MeV} \approx 20 \text{ ft}$ ).

The skin dose rate from a uniform thin deposition of  $1 \mu\text{Ci/cm}^2$  is about 9 rem/hr for energies above 0.6 MeV.

For a beta emitter point source, the dose rate in rem/hr at one foot is approximately  $300 \times \text{Ci}$  where Ci is the source strength in curies. This calculation neglects any shielding provided by the air, which can be significant. For example, the maximum range in air for a beta from S-35 is less than one foot, so the dose rate at one foot is zero for any size S-35 source.

### GAMMAS AND X-RAYS

For a point source gamma emitter with energies between 0.07 and 2 MeV, the exposure rate in R/hr at 1 foot is approximately  $6CEn$ , where C is the activity in curies; E is the energy in MeV; and n is the number of gammas per disintegration.

Gammas and x-rays up to 2 MeV will be attenuated by at least a factor of 10 by 2 inches of lead.

## Appendix C EXCERPT FROM USNRC REGULATORY GUIDE 8.29 – INSTRUCTION CONCERNING RISKS FROM OCCUPATIONAL RADIATION EXPOSURE<sup>1</sup>

Section 19.12 of 10 CFR Part 19, "Notices, Instructions and Reports to Workers: Inspection and Investigations," requires that all individuals working in or frequenting any portion of a restricted area be instructed in the health protection problems associated with exposure to radioactive materials or radiation. Section 20.1206 of 10 CFR Part 20, "Standards for Protection Against Radiation," requires that before a planned special exposure occurs the individuals involved are, among other things, to be informed of the estimated doses and associated risks.

This Revision 1 to Regulatory Guide 8.29 is being developed to describe the information that should be provided to workers by licensees about health risks from occupational exposure. This Revision I will conform to the revision of 10 CFR Part 20 that became effective on June 20, 1991, and was required to be implemented by licensees no later than January 1, 1994. The revision of 10 CFR Part 20 changed the occupational dose limits for adults and minors, provided for planned special exposures, established a dose limit for an embryo/fetus of an occupationally exposed declared pregnant woman and explicitly states that Part 20 is not to be construed as limiting action that may be necessary to protect health and safety during emergencies.

The scientific community generally accepts that exposure to ionizing radiation can cause biological effects that may be harmful to the exposed person. These effects may be classified into three categories:

- ◆ **Somatic Effects:** Physical effects occurring in the exposed person. These may be early effects that are observable soon after a large or acute dose (e.g., 100 rems (1 Sv) or more to the whole body in a few hours); or they may be delayed effects such as cancer that may occur years after exposure to radiation.
- ◆ **Genetic Effects:** Abnormalities that may occur in the future children of exposed individuals and in subsequent generations.
- ◆ **Teratogenic Effects:** Effects that may be observed in children who were exposed during the fetal and embryonic stages of development.

To avoid or limit these biological effects, regulatory controls are imposed on occupational doses to adults and minors and on doses to the embryo/fetus from occupational exposures of declared pregnant women.

Radiation protection training for all workers who may be occupationally exposed to ionizing radiation is an essential component of any program designed to ensure compliance with NRC regulations. A clear understanding of what is presently known about the biological risks associated with exposure to radiation will result in more effective radiation protection training and should generate more interest on the part of the workers in complying with radiation protection standards. In addition, pregnant women and other occupationally exposed workers should have whatever information on radiation risk is available to enable them to make informed decisions regarding the acceptance of these risks. It is intended that workers who receive this instruction will develop a healthy respect for the risks involved rather than either excessive fear or indifference.

Strong management support is considered essential to an adequate radiation protection training program. Instruction to workers performed in compliance with 10 CFR 19.12 should be given prior to occupational exposure and periodically thereafter. If a worker is to participate in a planned special exposure, in compliance with 10 CFR 20.1206 the worker should be informed of the associated risks. In providing instruction concerning health protection problems associated with exposure to radiation, all occupationally exposed workers and their supervisors should be given specific instruction on the risk of biological effects resulting from exposure to radiation. The instruction should be presented both orally and in printed form to workers and supervisors. The information and instruction that would be adequate to demonstrate compliance with these requirements in 10 CFR Parts 19 and 20 should be discussed during

---

<sup>1</sup>Material in Appendix C is extracted from Proposed Revision 1 to Regulatory Guide 8.29

training sessions in which each individual is given an opportunity to ask questions. Each trainee should be asked to acknowledge in writing that the instruction has been received and understood.

## **Instruction Concerning Risks from Occupational Radiation Exposure**

This instructional material is intended to provide the user with the best available information about the health risks from occupational exposure to ionizing radiation. Ionizing radiation consists of energy or small particles, such as gamma rays and beta or alpha particles, emitted from radioactive materials, which can cause chemical or physical damage when absorbed by living tissue. A question and answer format is used. Many of the questions or subjects initially were developed by the NRC staff in consultation with workers, union representatives, and licensee representatives experienced in radiation protection training.

This Revision 1 to Regulatory Guide 8.29 updates earlier material on biological effects and risks and on typical occupational exposure. Additionally, it conforms to the revised 10 CFR Part 20, "Standards for Protection Against Radiation," which was required to be implemented by licensees no later than January 1, 1994. The information in this appendix is intended to help develop an attitude of healthy respect for the risks associated with radiation, with neither unnecessary fear nor lack of concern. Additional guidance concerning other topics in radiation protection training is provided in other NRC regulatory guides.

### ***1. What is meant by health risk?***

A health risk is generally thought of as something that may endanger health. Scientists consider health risk to be the statistical probability or mathematical chance that personal injury, illness, or death may result from some action. Most people do not think about health risks in terms of mathematics. Instead, most of us consider the health risk of a particular action on the basis of whether we believe that particular action will, or will not, cause us some harm. The intent of this appendix is to provide estimates of, and explain the bases for, the possible risk of injury, illness, or death from occupational radiation exposure.

When x-rays, gamma rays, and ionizing particles interact with living materials such as our bodies, they might deposit energy sufficient to cause damage. Radiation can cause several different types of damage, such as very small physical displacement of molecules or a change of an atom to a different element, or ionization, which causes electrons to be removed from atoms and molecules. When the energy of these radiations is high enough, biological damage can occur: chemical bonds can be broken and cells can be damaged or killed.

The basic unit for measuring absorbed radiation is the rad (radiation absorbed dose). One rad (0.01 gray in the International System of units) equals the absorption of 100 ergs (a small but measurable amount of energy) in a gram of tissue exposed to radiation. To reflect biological risk, rads must be converted to rems. This conversion accounts for the differences in the effectiveness of different types of radiation to cause damage. The rem is used to estimate biological risk.

### ***2. What are the possible health effects of exposure to radiation?***

Potential health effects from exposure to radiation include cancer such as leukemia and bone, breast, and lung cancer. Very high, acute levels of radiation exposure have been known to cause prompt (or early) effects, such as vomiting and diarrhea, skin burns, cataracts, and even death. Radiation exposure has also been linked with the potential for genetic effects in future children of exposed parents. Children who were exposed to elevated levels of radiation prior to birth have shown an increased probability of mental retardation. These effects (with the exception of genetic effects) have been observed in studies of medical radiologists, uranium miners, radium workers, radiotherapy patients, and the people exposed to radiation from atomic bombs dropped on Japan. In addition, the radiation effects studies with laboratory animals have provided extensive data on radiation-induced health effects, including genetic effects.

The observations and studies mentioned above involve levels of radiation exposure or exposure rates that are generally higher than those received occupationally today. Although studies have not shown a clear cause-and-effect relationship between current levels of occupational radiation exposure and biological effects, it is prudent to assume that some effects do occur.

### 3. *What is meant by early and continuing effects, delayed effects, and genetic effects?*

#### **Early and Continuing Effects**

Early effects, which are also called immediate or prompt effects, are those that occur shortly after an exposure, within hours to a few days. They are observable after receiving a very large dose in a short period of time -- for example, 300 rems (3 Sv) received within a few minutes to a few days. Early effects are not caused at the levels of radiation exposure allowed under the NRC's occupational limits.

Early effects occur when the radiation dose is large enough to cause extensive biological damage to cells; a large number of cells within a specific organ or the whole body will have been killed. For prompt effects to occur, this radiation dose must be received within a short time period. This type of dose is called an *acute dose* or *acute exposure*. The same dose received over a long time period would not necessarily cause the same effect. Our body's natural biological process is constantly repairing damaged cells and replacing dead cells; if the cell damage is not severe, our body is capable of repairing and replacing the damaged cells without any observable adverse conditions.

For example, a whole body dose of about 300 rems (3 Sv), 60 times the annual occupational dose limit, if received within a short time period (e.g., a few hours) will cause vomiting and diarrhea within a few hours; loss of hair, fever, and weight loss within a few weeks; and about a 50 percent chance of death without medical treatment. These effects would not occur if the dose of 300 rems (3 Sv) were accumulated gradually over many years.

It is important to distinguish between whole body and partial body exposure. A localized dose to a small area of the body would not produce the same effect as a whole body dose of the same magnitude. For example, if only the hand were exposed, the effect would mainly be limited to a portion of the skin and underlying tissue of the hand. An acute dose of 600 rem (6 Sv) to the hand would cause skin reddening; recovery would occur over the following months and no long-term damage would be expected. An acute dose of this magnitude to the whole body could cause death within a short time without medical treatment. Medical treatment would lessen the magnitude of the effects and the chance of death; however, it would not totally eliminate the effects or the chance of death.

Cataracts are also considered early and continuing effects. A certain level of dose to the lens of the eye is required before any observable visual impairment is observed and the impairment remains after the exposure is stopped. The threshold for cataract development is an acute dose on the order of 100 rem (1 Sv). Further, a cumulative dose of 800 rems (8 Sv) from protracted exposures over many years to the lens of the eye has also been linked to some level of visual impairment. This dose exceeds the amount that can be accumulated by the lens for normal occupational exposure.

#### **Delayed Effects**

Delayed effects may occur years after exposure. These effects are not the immediate, direct result of biological damage to the cells of the body but are caused indirectly when the radiation causes the cells in the body to change, thereby causing the normal function of the cell to change -- for example, turning normal healthy cells into cancer cells. The potential for these delayed health effects is one of the main concerns addressed when setting limits for occupational doses.

#### **Genetic Effects**

Genetic effects can occur when there is radiation damage to the genetic material. These effects may show up as birth defects or other conditions in the future children of the exposed individual and succeeding generations. However, excess genetic effects clearly caused by radiation have not been observed in human populations exposed to radiation. Continuing evaluations of the atomic bomb survivors (Hiroshima and Nagasaki) have not shown any significant radiation-related increases in genetic defects. Effects have been observed in animal studies conducted at very high levels of exposure and it is known that radiation can cause changes in the genes in cells of the human body. Therefore, it is prudent to assume that radiation exposures, even at the levels allowed under the NRC's limits, do pose some risk of genetic effects. *Teratogenic effects*, or effects that are observable in children who were exposed during the fetal and embryonic stages of development, are discussed in Question 5.

### 4. *What is the difference between the effects of acute and chronic radiation exposure?*



Acute radiation doses usually refer to a large dose of radiation received in a short period of time. **Chronic exposure** refers to small doses received repeatedly over long time periods, for example, 20 to 100 mrem (or millirem, which is one-thousandth of a rem) (0.2 to 1 mSv) per week every week for several years. It is assumed that any radiation exposure, either acute or chronic, has a potential for causing delayed effects. However, only acute doses cause early effects; chronic doses do not cause early effects. Since NRC limits are set to prevent all early effects, concern with occupational radiation risk is primarily focused on chronic exposure to low levels of radiation over long time periods for which the delayed effects such as cancer are of concern.

The difference between acute and chronic radiation exposure can also be shown by a comparison with exposure to the sun's rays. An intense exposure to the sun can result in painful burning, peeling, and growing of new skin. However, repeated short exposures provide time for the skin to repair between exposures. Whether exposure to the sun's rays is long term or spread over short periods, some of the injury may not be repaired and may eventually result in skin cancer.

#### **5. What are the health risks from radiation exposure to the embryo/fetus?**

During certain stages of development, the embryo/fetus is much more sensitive to radiation than adults are. Studies of atomic bomb survivors exposed to high radiation doses during pregnancy show that children born after these exposures have a higher risk of mental retardation or lower IQ scores. Other studies suggest that an association exists between exposure to diagnostic x-rays before birth and carcinogenic effects in adult life; the magnitude of the risk, however, is uncertain. In recognition of this increased radiation sensitivity, a more restrictive dose limit has been established for the embryo/fetus of a **declared pregnant** radiation worker. Guidance in conformance with the revised 10 CFR Part 20 is being developed as a proposed Revision 3 to Regulatory Guide 8.13; it has been published as Draft Regulatory Guide DG-8014, "Instruction Concerning Prenatal Radiation Exposure."

If an occupationally exposed woman declares her pregnancy to the licensee, she is subject to the more restrictive dose limits for the embryo/fetus during the remainder of the pregnancy. The dose limit of 500 mrem (5 mSv) for the total gestation period applies to the embryo/fetus and is controlled by restricting the exposure to the declared pregnant woman. Restricting the woman's occupational exposure, if she declares her pregnancy, raises questions about individual privacy rights, equal employment opportunities, and possible loss of income. Because of these concerns, the declaration of pregnancy by a woman radiation worker is voluntary. Also, the declaration of pregnancy can be withdrawn, for example, if the woman reconsiders and feels that her benefits from receiving the occupational exposure would outweigh the increased risk to her embryo/fetus from the radiation exposure.

#### **6. Can a worker become sterile or impotent from normal occupational radiation exposure?**

No. Temporary or permanent sterility can be caused by radiation but not at the levels allowed under NRC's occupational limits. Sterility is an early radiation effect. There is a threshold below which these effects would not occur. Doses on the order of 10 rem (0.1 Sv) to the testes can result in a measurable but temporary reduction in sperm count. Temporary sterility (suppression of ovulation) has been observed in women who have received acute doses of 150 rem (1.5 Sv). The estimated threshold (acute) radiation dose for induction of permanent sterility is about 200 rem (2 Sv) for men and about 350 rem (3.5 Sv) for women.

Although high, acute doses can affect fertility, they have no direct effect on the ability to function sexually. No evidence exists that exposures within the NRC's occupational limits have any direct effect on the ability to function sexually.

#### **7. What is meant by external and internal exposure?**

A worker's occupational dose may be caused by exposure to radiation that originates outside the body, called **external exposure**, or by exposure to radiation from radioactive material that has been taken into the body, called **internal exposure**. It is the current scientific consensus that a rem of radiation dose has the same biological risk regardless of whether it is from an external or an internal source. The NRC requires that dose for external exposure and dose for internal exposure be added together to determine

compliance with occupational limits. The sum of external and internal dose is called the **Total Effective Dose Equivalent (TEDE)**.

Radioactive materials may enter the body through breathing, eating, or drinking, or they may be absorbed through the skin, particularly if the skin is broken. The intake of radioactive materials by workers is generally due to breathing contaminated air. Radioactive materials may be present as fine dust or gases in the workplace atmosphere. The surfaces of equipment and workbenches may be contaminated and these materials can be resuspended in air during work activities.

After entering the body, the radioactive material goes to particular organs, depending on the biochemistry of the material. For example, certain chemical forms of uranium tend to deposit in the bones, where they remain for a long time. These forms of uranium are slowly eliminated from the body, mostly by way of the kidneys. Radioactive iodine is preferentially deposited in the thyroid gland, which is located in the neck.

To limit risk to specific organs and the total body, standards have been established for the **annual limit of intake (ALI)** for each radionuclide. When more than one radionuclide is involved, the intake amounts of each are reduced proportionally. NRC regulations specify the concentrations of radioactive material in the air to which a worker can be continuously exposed for the entire 2,000 working hours in a year. These concentrations are termed the **derived air concentrations (DACs)**. These limits are the total amounts allowed if no external radiation is received. The resulting dose from the internal radiation sources is the maximum allowed to the organ or to the worker's whole body.

### 8. **How does radiation cause cancer?**

When radiation interacts with the cells of our bodies, a number of events can occur. The damaged cells can repair themselves; no resulting damage is caused. The cells can die, much like the millions of cells that die every day in our bodies, and may be replaced through the normal biological process. Or a change can occur in the cell's reproductive structure -- the cells can mutate and subsequently be repaired with no effect, or they can form precancerous cells, which may become cancerous.

Radiobiologists have studied the relationship between radiation and cancer. These studies indicate that radiation damage to chromosomes in the cell nucleus is the main cause of cancer. Chromosome damage may occur directly through the interaction of the ionizing radiation in the cell or indirectly through reactions of chemical products produced by radiation interactions. Cells are able to repair most damage within hours; however, misrepair may occur. Such misrepaired damage is thought to be the origin of cancer, but misrepair does not always cause cancer. Benign changes in the cell can occur or the cell can die; these changes do not lead to cancer.

Many factors can affect susceptibility to the cancer, causing effects of radiation, such as age, general health, inherited traits, sex, as well as exposure to other cancer-causing agents such as cigarette smoke. However, most diseases are caused by the interaction of several factors. Other detrimental conditions such as smoking appear to increase the susceptibility.

### 9. **If I receive a radiation dose, will it cause me to get cancer?**

Probably not. Radiation is like most substances that cause cancer in that the effects can be seen clearly only at high doses. Assessment of the cancer risks that may be associated with low doses of radiation are projected from data available at doses larger than 10 rad (0.1 gray). Generally, for radiation protection purposes, these estimates are made using the straight line portion of the linear quadratic model. We have data on cancer probabilities for high doses as shown by the solid line in the graph. Only in the studies of radiation above occupational limits are there dependable measurements of risk of cancer, primarily because below the limits the effect is

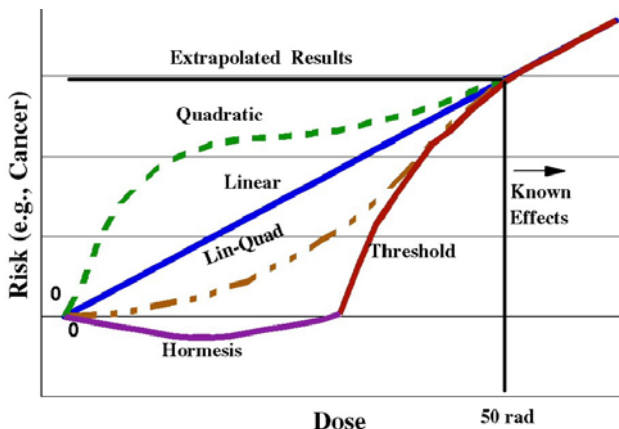

small compared to differences in the normal cancer incidence from year to year and place to place. Most scientists believe that there is some risk no matter how small the dose. Some scientists believe that the risk drops off to zero at some low dose, the threshold effect. A few believe that risk levels off so that even very small doses imply a significant risk. The majority of scientists today endorse the linear quadratic model.

For regulatory purposes, the NRC uses the straight line portion of the linear quadratic model, which shows the number of effects decreasing as the dose decreases. It is prudent to assume that even small doses have some chance of causing cancer. This is as true for natural carcinogens such as sunlight and natural radiation as it is for those that are man-made such as cigarette smoke, smog, and man-made radiation. Thus, a principle of radiation protection is to do more than merely meet the allowed regulatory limits; doses should be kept as low as is reasonably achievable (*ALARA*). The ALARA concept is discussed in Question 13.

**10. What are the estimates of the risk of cancer from radiation exposure?**

We don't know exactly what the chances are of getting cancer from a low-level radiation dose, but we can make estimates based on extensive scientific research knowledge. We do know that the estimates of radiation effects are better known and are more certain than are those of most hazardous chemicals. Being exposed to typical occupational radiation doses is taking a chance, but that chance is reasonably well understood. From currently available data, the NRC has adopted the risk value for an occupational dose of 1 rem (0.01 Sv) as representing a risk of 4 in 10,000 of developing a fatal cancer.

Not all workers incur the same level of risk. The radiation risk incurred by a worker depends on the amount of dose received. Under the linear model explained above, a worker who receives 5 rems (0.05 Sv) in a year incurs 10 times as much risk as another worker who receives only 0.5 rem (0.005 Sv). Only a very few workers receive doses near 5 rems (0.05 Sv) per year.

According to the BEIR V report, approximately one in five adults normally will die from cancer from all possible causes such as smoking, food, alcohol, drugs, air pollutants, natural background radiation, and inherited traits. Thus, in any group of 10,000 workers, we can estimate that about 2,000 will die from cancer in the absence of any occupational radiation exposure. As stated earlier, there is a risk of 4 in 10,000 of a 1-rem (0.01 Sv) dose causing a fatal cancer. Another way of stating this risk of a fatal cancer is 1 in 2,500 per rem (0.01 Sv) received, or 0.0004 per rem (0.01Sv).

To explain the significance of these estimates, we will use a group of 10,000 people, each exposed to 1 rem (0.01 Sv) of ionizing radiation. In this group of 10,000 workers, we could estimate that 4 would die from cancer because of that dose in addition to the 2,000 normal incidents, although the actual number could be more or less than 4. These deaths would be in addition to the natural death rate for cancer, which is 1 in 5 people. This means that a 1-rem (0.01 Sv) dose to each of 10,000 workers might increase each individual worker's chances of dying from cancer from 20 percent to 20.04 percent. If one's lifetime occupational dose is 10 rems, we could raise the estimate to 20.4 percent. A lifetime dose of 100 rems may have increased your chances of dying from cancer from 20 to 24 percent. The average measurable dose for radiation workers reported to the NRC was 0.3 rem (0.003 Sv) for 1992. Today, very few workers ever accumulate 100 rems (1 Sv) and the average career dose of workers at NRC-licensed facilities is 1.5 rem (0.015 Sv), which represents an increased risk of dying from cancer from 20 to about 20.06 percent.

It is important to understand the probability factors here. A similar question would be, "If you select one card from a full deck, will you get the ace of spades?" This question cannot be answered with a simple yes or no. The best answer is that your chance is 1 in 52. However, if 1000 people each select one card from full decks, we can predict that about 20 of them will get an ace of spades. Each person will have 1 chance in 52 of drawing the ace of spades, but there is no way we can predict which persons will get the right card. The issue is further complicated by the fact that in a drawing by 1000 people, we might get only 15 successes, and in another, perhaps 25 correct cards in 1000 draws. We can say that if you receive a radiation dose, you will have increased your chances of eventually developing cancer. It is assumed that the more radiation exposure you get, the more you increase your chances of cancer.

The normal chance of dying from cancer is about one in five for persons who receive no occupational radiation dose. The additional chance of developing fatal cancer from an occupational exposure of 1 rem (0.01 Sv) is about the same as the chances of drawing an ace from a full deck of cards three times in a row. The additional chance of dying from cancer from an occupational exposure of 10 rem (0.1 Sv) is about equal to your chance of drawing two aces successively on the first two draws from a full deck of cards.

It is important to realize that these risk numbers are only estimates. Many difficulties are involved in designing research studies that can accurately measure the projected small increases in cancer cases that might be caused by low exposures to radiation as compared to the normal rate of cancer. There is still uncertainty with regard to estimates of radiation risk from low levels of exposure. The numbers used here result from studies involving high doses and high dose rates.

These estimates are considered by the NRC staff to be the best available for the worker to use to make an informed decision concerning acceptance of the risks associated with exposure to radiation. A worker who decides to accept this risk should try to keep exposure to radiation as low as is reasonably achievable (ALARA) to avoid unnecessary risk.

Estimated Loss of Life Expectancy from ...

Table 1. Health Risks

Health Risk	Life Expectancy Lost
Smoking 20 cigarettes a day	6 years
Overweight (by 15%)	2 years
Alcohol consumption (US average)	1 year
All accidents combined	1 year
Motor vehicle accidents	207 days
Home accidents	74 days
Drowning	24 days
Natural hazards (earthquake, flood, etc.)	7 days
Medical radiation	6 days
Occupational exposure	
0.3 rem/y from age 18 to 65	15 days
1 rem/y from age 18 to 65	51 days

Table 2. Industrial Accidents

Industry Type	Average Life Expectancy Lost
All industries	60 days
Agriculture	320 days
Construction	227 days
Mining / Quarrying	167 days
Transportation and Public Utilities	160 days
Government	60 days
Manufacturing	40 days
Trade	27 days
Services	27 days

**11. How can we compare radiation risk to other kinds of health risks?**

Perhaps the most useful way to make these comparisons is to compare the average number of days of life expectancy lost per unit of exposure to each particular health risk. Estimates are calculated by looking at a large number of persons, recording the age when death occurs from apparent causes, and estimating the average number of days of life lost as a result of these early deaths. The total number of days of life lost is then averaged over the total group observed.

Several studies have compared the projected average loss of life expectancy resulting from exposure to radiation with other health risks. The word average is important because an individual who gets cancer loses about 15 years of life expectancy, while his or her coworkers suffer no loss.

Some representative numbers are presented in Table 1. For the NRC-regulated industries, the average measurable occupational dose in 1992 was 0.3 rem (0.003 Sv). A simple Calculation based on the article by Cohen and Lee shows that 0.3 rem (0.003 Sv) per year from age 18 to 65 results in a projected estimate of life expectancy loss of 15 days. These estimates indicate that the health risks from occupational radiation exposure are smaller than the risks associated with many other events or activities we encounter and accept in normal day-to-day activities.

Another useful comparison is to look at estimates of the average number of days of life expectancy lost from occupational exposure to radiation and to compare this number with days lost for several types of industries. Table 2 shows average days of life expectancy lost as a result of fatal work-related accidents. Table 2 does not include nonaccident types of occupational risks such as occupational disease and stress.

### ***12. What are the NRC occupational dose limits?***

**For adults**, an annual limit that does not exceed:

- 5 rems (0.05 Sv) for the Total Effective Dose Equivalent (TEDE), which is the sum of doses from external exposure to the whole body and from the equivalent internal doses from intakes of radioactive material. Doses to an organ or tissue must be multiplied by risk-weighting factors to compare the dose to a whole body exposure before they are added to the external dose.
- 50 rems (0.5 Sv) for the Total Organ Dose Equivalent (TODE), which is the sum of doses from external exposure to the whole body and the dose from intakes of radioactive material to any individual organ or tissue, other than the lens of the eye.
- 15 rems (0.15 Sv) for the Lens Dose Equivalent (LDE), which is the external dose to the lens of the eye.
- 50 rems (0.5 Sv) for the Shallow Dose Equivalent (SDE), which is the external dose to the sensitive portion of the skin or to any extremity.

**For minors**, the annual occupational dose limits are 10 percent of the dose limits for adult workers.

**For the embryo/etus** of a declared pregnant woman, the dose limit is 0.5 rem (5 mSv) during the entire pregnancy.

The occupational dose limit for adult workers of 5 rem (0.05 Sv) TEDE is based on consideration of potential delayed biological effects. The 5-rem (0.05 Sv) limit, together with application of the concept of keeping occupational doses ALARA, provides a level of risk of delayed effects considered acceptable by the NRC. The limits for individual organs are below the levels of observed early biological effects in the respective organs.

The dose limit for the embryo/fetus of a declared pregnant woman is based on consideration of the special sensitivity to radiation of the embryo/fetus. This limit is in effect only when a woman declares her pregnancy in writing to the licensee

### ***13. What is meant by ALARA?***

ALARA means "as low as is reasonably achievable." In addition to providing an upper limit on an individual's permissible radiation exposure, the NRC requires that its licensees establish radiation protection programs for maintaining occupational exposures, and exposures to the public, as far below the limit as is reasonably achievable. Reasonably achievable also means practical. What is practical depends on the purpose of the job, the state of technology, the costs for reducing the exposures, and the benefits. Although ALARA is a required integral part of each licensee's radiation protection program, it does not establish an occupational dose limit.

In practice, ALARA includes planning tasks involving radiation exposure so as to reduce exposure to individual workers, the work group, and those who, although not part of the work group, may be exposed as a result of the work group's actions. Work practices should be reviewed with the objective of preventing unnecessary exposures.

There are several ways to control radiation doses, e.g., limiting the time in radiation areas, maintaining distance from sources of radiation, and providing shielding of radiation sources to reduce dose rates. The use of engineered controls is also a requirement of the ALARA concept -- from the design of facilities and equipment to the actual set-up and conduct of work activities.

The ALARA concept should also be used in determining the appropriate use of respiratory protection. To the extent practical, engineering controls such as containments and ventilation systems should be used to reduce workplace airborne radioactive materials. In evaluating whether or not to use respirators, the ALARA goal is to achieve the lowest sum of external and internal doses. For example, the use of respirators can lead to increased work time within radiation areas, which increases external dose. The

advantage of using respirators to reduce internal exposure must be evaluated against the increased external exposure caused by longer working times. The goal is to maintain total exposure ALARA.

Table 3. Average US Annual Dose Equivalent

Source	Dose Equivalent
Natural	
Radon	200 mrem
Other than Radon	100 mrem
Total	300 mrem
Nuclear Fuel Cycle	0.05 mrem
Consumer Products <sup>1</sup>	9 mrem
Medical	
Diagnostic X-ray	39 mrem
Nuclear Medicine	14 mrem
Total	53 mrem
Total	≈360 mrem/yr

<sup>1</sup>Includes tobacco, building materials, TV, smoke detectors, etc.

Table 4. Reported Occupational Doses for 1992

Occupational Subgroup	Average dose per Worker
Industrial radiography	490 mrem
Manufacturing / distribution	260 mrem
Low-level waste disposal	450 mrem
Independent spent fuel storage	130 mrem
Fuel fabrication	110 mrem
Commercial power reactors	310 mrem

**14. How much radiation does the average person who does not work in the nuclear industry receive?**

The average person is constantly exposed to ionizing radiation from several sources. Our environment and even the human body contain naturally occurring radioactive materials (e.g., potassium-40 and thorium) that contribute to the radiation we receive. The largest source of human radiation exposure is terrestrial radon, a colorless, odorless, chemically inert gas, which causes about 55 percent of our average, nonoccupational exposure. Cosmic radiation originating in space and in the sun contributes additional exposure. The use of x-rays and radioactive materials in medicine and dentistry adds to our population exposure. As shown below in Table 3, the average person receives an annual radiation dose of about 0.36 rem (3.6 mSv). By age 20, the average person will accumulate over 7 rems (70 mSv) of dose. By age 50, the total dose is up to 18 rems (180 mSv). After 70 years of exposure this dose is up to 25 rems (250 mSv).

**15. What are the typical radiation doses received by workers?**

For 1992, the NRC received reports on about a quarter of a million people who were monitored for occupational exposure to radiation. Almost half of those monitored had no measurable doses. The other half had an average dose of about 300 mrem (3 mSv) for the year. Of the total group of about a quarter of a million people, 97 percent received an annual dose of less than 1 rem (10 mSv); 99.7 percent received less than 2 rems (20 mSv); and the highest reported dose was for an individual who received between 5 and 6 rems (50 and 60 mSv).

Table 4 lists average occupational doses for workers (persons who had measurable doses) in various occupations based on 1992 data.

**16. How do I know how much my dose (exposure) is?**

The NRC requires your employer, the NRC licensee, to determine your exposure, to maintain records of your exposure, and, at least on an annual basis, to inform you of your exposure.

External exposures are monitored by using individual monitoring devices. These devices are required to be used if it appears likely that your external exposure will exceed 10 percent of your allowed annual dose. The most commonly used monitoring devices are film badges, thermoluminescent dosimeters (TLDs), electronic dosimeters, and direct reading pocket dosimeters.

With respect to internal exposure, your employer is required to monitor your occupational intake of radioactive material and assess the dose if it appears likely that you will receive greater than 10 percent of

the annual limit on intake (ALI) if you are an adult, or a dose in excess of 0.05 rem (0.5 mSv) from intakes in one year if you are a minor or a declared pregnant worker. Internal exposure can be estimated by measuring the radiation emitted from the body (for example, with a "whole body counter") or by measuring the radioactive materials contained in biological samples such as urine or feces. Dose estimates can also be made if one knows how much radioactive material is in the air and the length of time during which the air was breathed.

**17. *What happens if a worker exceeds the annual dose limit?***

The regulations do not permit any additional occupational exposure to a person who is exposed in excess of the limit during the remainder of the year in which the limit is exceeded. The licensee is also required to file an overexposure report with the NRC and provide a copy to the individual. The licensee will be subject to NRC enforcement action (possibly a fine), just as you are subject to a traffic fine for exceeding the speed limit. The fines and, in some serious or repetitive cases, suspension of license are intended to encourage efforts to operate within the limits.

Radiation protection limits such as 5 rems (0.05 Sv) a year are not absolute limits that determine safe or unsafe levels of radiation exposures. Exceeding this limit does not mean that you will necessarily be harmed. It is assumed that risks are related to the size of the radiation dose. Therefore, when your dose is higher your risk is also higher. These limits are similar to highway speed limits. If you drive at 70 mph, your risk is higher than at the 55 mph limit, even though you may not actually have an accident. Those who set speed limits have determined that the risks of driving in excess of the speed limit are not acceptable. In the same way, the revised 10 CFR Part 20 establishes a limit for normal occupational exposures of 5 rems (0.05 Sv) a year. Although you will not necessarily get cancer or some other radiation effect at doses above the limit, it does mean that the licensee's safety program has failed in some way. Investigation is warranted to determine the cause and correct the conditions leading to the exposure in excess of the limit.

Risks from higher doses that might be incurred in exceptional situations or emergencies are explained in Questions 19 and 22.

**18. *Is the use of extra workers a good way to reduce dose?***

There is a "yes" answer to this question and a "no" answer. For a given job involving exposure to radiation, the more people who share the work, the lower the average dose to individuals. The less the dose, the less the risk. So, for you as an individual, the answer is "yes."

But how about the risk to the entire group of workers? Under assumptions used by the NRC for purposes of protection, the risk of cancer depends on the total amount of radiation energy absorbed by human tissue, not on the number of people to whom this tissue belongs. Therefore, if 30 workers are used to do a job instead of 10, and if both groups get the same collective dose (person-rems), the total cancer risk is the same, and nothing was gained for the group by using 30 workers. From this viewpoint the answer is "no." The risk was not reduced but simply spread around among a larger number of persons.

Unfortunately, spreading the risk around often results in a larger collective dose for the job. Workers are exposed as they approach a job, while they are getting oriented to do the job, and as they withdraw from the job. The dose received during these actions is called nonproductive. If several crew changes are required, the nonproductive dose can become very large.

The use of extra workers may actually increase the total occupational dose and the resulting collective risks. The use of extra workers may not be the way to reduce the risk of radiation-induced cancer for the worker population. At best, the total risk remains the same, and it may even be increased. The best way to reduce the risk is to reduce the collective dose; that can be done only by reducing radiation levels, working times, or both.

**19. *What is meant by a planned special exposure?***

A "planned special exposure" means an infrequent exposure to radiation, separate from, and in addition to, the doses received under the annual limits. The licensee can authorize additional dose that is equal to the annual occupational dose limits as long as the individual's total dose does not exceed five times the annual dose limits during the individual's lifetime. For example, licensees may authorize "planned special exposures" for an adult radiation worker to receive doses up to an additional 5 rems (0.05 Sv) in a year above the 5-rem (0.05 Sv) annual TEDE occupational dose limit. Each worker is limited to no more than 25 rems (0.25 Sv) from planned special exposures in his or her lifetime. Such exposures are only allowed in exceptional situations when alternatives for avoiding the additional



exposure are not available or are impractical. Before the licensee grants approval, the licensee must ensure that the worker is informed of the purpose and circumstances for the planned operation, the estimated doses expected, and the procedures to keep the doses ALARA while considering other risks that may be present.

**20. Why do some facilities establish administrative limits that are below the NRC limits?**

There are two reasons. First, the NRC regulations state that licensees should keep exposures to radiation ALARA. By requiring specific approval for worker doses in excess of set levels, more careful risk-benefit analyses can be made as each additional increment of dose is approved for a worker. Secondly, an administrative limit that is set lower than the NRC limit provides a safety margin designed to help the licensee avoid exposures in excess of the limit.

**21. Why aren't medical exposures considered as part of a worker's allowed dose?**

NRC rules exempt medical exposure, but equal doses of medical and occupational radiation have equal risks. Medical exposure to radiation is justified for reasons that are quite different, however, from those applicable to occupational exposure. A physician prescribing an x-ray should be convinced that the benefit to the patient from the resulting medical information justifies the risk associated with the radiation. Each worker must decide, however, on the benefits and acceptability of occupational radiation risk, just as each worker must decide on the acceptability of any other occupational hazard.

For another point of view, consider a worker who receives a dose of 2 rems (0.02 Sv) from a series of x-rays or a radioactive medicine in connection with an injury or illness. This dose and the implied risk should be justified on medical grounds. If the worker had also received 4 rems (0.04 Sv) on the job, the combined dose of 6 rems (0.06 Sv) would not incapacitate the worker. A dose of 6 rems (0.06 Sv) is not especially dangerous and is not large compared to the allowed cumulative occupational dose. Restricting the worker from additional job exposure during the remainder of the year would have no effect one way or the other on the risk from the 2 rems (0.02 Sv) already received from medical exposure. If the individual worker accepts the risks associated with the x-rays on the basis of the medical benefits and accepts the risks associated with job-related exposure on the basis of employment benefits, it would be unfair to restrict the worker from employment in radiation areas for the remainder of the year.

**22. How should radiation risks be considered in an emergency?**

Although the use of planned special exposures allows an additional 5 rems (0.05 Sv) a year for special occasions, that allowance does not apply to emergencies. Emergencies are "unplanned" events in which actions to save lives or property may warrant additional doses for which no particular limit applies. Even though the revised 10 CFR Part 20 does not set any dose limits for lifesaving activities, workers should remember that radiation risks increase with increasing dose and that the ALARA principle applies for emergencies as well as routine activities. In addition, any doses received during emergencies have to be reported to the NRC and included on the worker's lifetime dose record. The NRC has not sanctioned any "forgivable" emergency dose that would not be counted in an individual worker's lifetime dose.

Table 5. Risk of Premature Death: 25-rem Exposure

Age at Exposure (years)	Estimated Risk of Premature Death (deaths per 1,000 Persons Exposed)
20 - 30	9.1
30 - 40	7.2
40 - 50	5.3
50 - 60	3.5

The Environmental Protection Agency (EPA) has published emergency dose guidelines. These guidelines state that doses to all workers during emergencies should, to the extent practicable, be limited to 5 rems (0.05 Sv). There are some emergency situations, however, for which higher emergency limits may be justified. Justification of any such exposure must include the presence of conditions that prevent the rotation of workers or other commonly used dose reduction methods. Except as noted below, the dose resulting from such emergency exposures should be limited to 10 rems (0.1 Sv) for protecting valuable property, and to 25 rems (0.25 Sv) for lifesaving activities and the protection of large populations. In the context of this guidance, exposure of workers that is incurred for the

protection of large populations may be considered justified for situations in which the collective dose avoided by the emergency operation is significantly larger than that incurred by the workers involved.



Situations may rarely occur in which a dose in excess of 25 rems (0.25 Sv) for emergency exposure would be unavoidable in order to carry out a lifesaving operation or to avoid extensive exposure of large populations. However, persons undertaking any emergency operation in which the dose will exceed 25 rems (0.25 Sv) to the whole body should do so only on a voluntary basis and with full awareness of the risks involved, including the numerical levels of dose at which prompt effects of radiation will be incurred and numerical estimates of the risks of delayed effects.

Table 5 presents the approximate risk of premature death for a group of 1,000 workers of various ages who have all received an acute dose of 25 rems (0.25 Sv). If needed, the referenced EPA source document should be used for training regarding risks of high doses.

Even under emergency conditions, licensees and radiation workers should make every effort to evaluate the potential exposures before authorizing additional necessary doses. To the extent possible in an emergency, workers should be informed of the situation and procedures to follow to keep exposures ALARA.

### ***23. Who developed the radiation risk estimates used in this guide?***

Radiation risk estimates were developed by several national and international scientific organizations over the last 40 years. These organizations include the National Academy of Sciences (which has issued five reports from the Committee on the Biological Effects of Ionizing Radiations, BEIR), the National Council on Radiation Protection and Measurements (NCRP), the International Commission on Radiological Protection (ICRP), and the United Nations Scientific Committee on Effects of Atomic Radiation (UNSCEAR). Each of these organizations continues to review new research findings on radiation health risks.

Several recent reports from these organizations present new findings on radiation risks based upon revised estimates of radiation dose to survivors of the atomic bombs at Hiroshima and Nagasaki. For example, UNSCEAR published revised risk estimates in 1988. The NCRP also published a report in 1988, *New Dosimetry at Hiroshima and Nagasaki and Its Implications for Risk Estimates*. In January 1990, the National Academy of Sciences released the fifth report of the BEIR Committee, *Health Effects of Exposure to Low Levels of Ionizing Radiation*. Each of these publications also provides extensive bibliographies on other published studies concerning radiation health effects for those who may wish to read further on this subject.

### ***24. How were radiation dose limits established?***

The NRC radiation dose limits in 10 CFR Part 20 were established by the rulemaking procedures required for Federal agencies. Under the rulemaking procedures, the NRC staff developed a proposed rule that was then reviewed and approved by the 5-member Commission that directs the NRC. Following the Commission's approval, the proposed rule was published in the Federal Register for public comment. The Federal Register may be considered to be the government's newspaper. Publication in the Federal Register provided legal notice to all persons that the NRC was considering setting new radiation dose limits.

In developing the proposed dose limits, the staff considered the 1987 Presidential Guidance on occupational exposure. That guidance was developed under the lead of the EPA. The guidance was signed by the President and was intended for use by all Federal agencies. The staff also considered the recommendations of the International Commission of Radiological Protection (ICRP) and its U.S. counterpart, the National Council on Radiation Protection and Measurements (NCRP).

In addition to publication of the proposed Part 20 in the Federal Register in January 1986, the NRC sent copies to all NRC licensees and to many other interested parties. More than 800 sets of comments were received and considered by the staff in developing the final rule.

Note that the proposed rule presented a tentative NRC position on radiation dose limits. The final rule was developed only after consideration of comments from licensees, labor unions, public interest groups, other Federal agencies, scientific organizations, and other interested parties.

### ***25. Several scientific reports have recommended that the NRC should use lower limits. Does the NRC plan to reduce the regulatory limits?***

Since publication of the proposed rule in 1986, the ICRP in 1990 revised its recommendations for radiation protection based on newer studies of radiation risks, and the NCRP followed with a revision to its recommendations in 1993. The ICRP recommended a limit of 10 rems (0.1 Sv) effective dose equivalent (from internal and external sources), over a 5-year period with no more than 5 rems (0.05 Sv) in 1 year. The NCRP recommended a cumulative limit, not to exceed 1 rem (0.01 Sv), times the individual's age with no more than 5 rems (0.05 Sv) in any year.

The NRC does not believe that additional reductions in the dose limits are urgently required. Because of the practice of maintaining radiation exposures ALARA ("as low as is reasonably achievable"), the average radiation dose to occupationally exposed persons is well below the limits in the current Part 20 that became mandatory January 1, 1994, and the average risks to radiation workers are below those limits recommended by the ICRP and the NCRP.

For example, in 1992, only a few workers (0.3 percent) in nuclear facilities reporting to the NRC received annual doses that exceeded 2 rems (0.02 Sv), and few are likely to exceed the 5-year limit recommended by the ICRP. The facilities included here were from six of the reporting industries that have the highest potential for occupational radiation exposures: nuclear power plants, industrial radiography, reactor fuel fabrication, low-level waste disposal, spent fuel storage, and radioisotope manufacturing. For another example, in 1992 about 97 percent of the same workers received annual doses of less than 1 rem (0.01 Sv), which provides reasonable assurance that cumulative dose limits based on age as proposed by the NCRP are being met.

The current dose limits contained in 10 CFR Part 20 are also consistent with the Federal guidance on occupational radiation exposure (described in Question 24), and any changes would be the subject of a future rulemaking.

**26. *What are my options if I decide the risks associated with occupational radiation exposure are too high?***

If the risks from exposure to radiation during your work are unacceptable to you, you could request a transfer to a job that does not involve exposure to radiation. However, the risks associated with the exposure to radiation that workers, on the average, actually receive are considered acceptable when compared to other occupational risks by virtually all the scientific groups that have studied them. From an NRC regulatory basis, your employer is not obligated to guarantee you a transfer if you decide not to accept an assignment that requires exposure to radiation.

You also have the option of seeking other employment in a nonradiation occupation. However, the studies that have compared occupational risks in the nuclear industry to those in other job areas indicate that nuclear work is relatively safe. Thus, you may find different kinds of risk but you will not necessarily find significantly lower risks in another job.

You and your employer should practice the most effective work procedures so as to keep your exposure ALARA. Be aware that reducing time of exposure, maintaining distance from radiation sources, and using shielding can all lower your exposure. Plan radiation jobs carefully to increase efficiency while in the radiation area. Learn the most effective methods of using protective clothing to avoid contamination. Discuss your job with the radiation protection personnel who can suggest additional ways to reduce your exposure.

**27. *Where can I get additional information on radiation risk?***

The following list suggests sources of useful information on radiation risk:

- Your employer - the radiation protection or health physics office where you are employed.
- Office of Radiation Control  
Alabama Department of Public Health  
PO Box 303017  
Montgomery, AL 36130-3017  
Telephone: (334) 206-5391 or (800) 582-1866
- U.S. Nuclear Regulatory Commission Headquarters  
Radiation Protection & Health Effects Branch

Office of Nuclear Regulatory Research  
Washington, DC 20555  
Telephone: (301) 415-6187

- Department of Health and Human Services  
Center for Devices and Radiological Health  
1390 Piccard Drive, MS HFZ-1  
Rockville, MD 20850  
Telephone: (301) 443-4690

## **Appendix D-1 EXCERPT FROM US NRC REGULATORY GUIDE 8.13 – INSTRUCTION CONCERNING PRENATAL RADIATION EXPOSURE<sup>2</sup>**

The Code of Federal Regulations in 10 CFR Part 19, "Notices, Instructions and Reports to Workers: Inspection and Investigations," in Section 19.12, "Instructions to Workers," requires instruction in "the health protection problems associated with exposure to radiation and/or radioactive material, in precautions or procedures to minimize exposure, and in the purposes and functions of protective devices employed." The instructions must be "commensurate with potential radiological health protection problems present in the work place."

The Nuclear Regulatory Commission's (NRC's) regulations on radiation protection are specified in 10 CFR Part 20, "Standards for Protection Against Radiation"; and 10 CFR 20.1208, "Dose to an Embryo/Fetus," requires licensees to "ensure that the dose to an embryo/fetus during the entire pregnancy, due to occupational exposure of a declared pregnant woman, does not exceed 0.5 rem (5 mSv)." Section 20.1208 also requires licensees to "make efforts to avoid substantial variation above a uniform monthly exposure rate to a declared pregnant woman." A declared pregnant woman is defined in 10 CFR 20.1003 as a woman who has voluntarily informed her employer, in writing, of her pregnancy and the estimated date of conception.

This regulatory guide is intended to provide information to pregnant women, and other personnel, to help them make decisions regarding radiation exposure during pregnancy. This Regulatory Guide 8.13 supplements Regulatory Guide 8.29, "Instruction Concerning Risks from Occupational Radiation Exposure" (see Appendix B-3), which contains a broad discussion of the risks from exposure to ionizing radiation.

Other sections of the NRC's regulations also specify requirements for monitoring external and internal occupational dose to a declared pregnant woman. In 10 CFR 20.1502, "Conditions Requiring Individual Monitoring of External and Internal Occupational Dose," licensees are required to monitor the occupational dose to a declared pregnant woman, using an individual monitoring device, if it is likely that the declared pregnant woman will receive, from external sources, a deep dose equivalent in excess of 0.1 rem (1 mSv). According to Paragraph (e) of 10 CFR 20.2106, "Records of Individual Monitoring Results," the licensee must maintain records of dose to an embryo/fetus if monitoring was required, and the records of dose to the embryo/ fetus must be kept with the records of dose to the declared pregnant woman. The declaration of pregnancy must be kept on file, but may be maintained separately from the dose records. The licensee must retain the required form or record until the Commission terminates each pertinent license requiring the record.

The information collections in this regulatory guide are covered by the requirements of 10 CFR Parts 19 or 20, which were approved by the Office of Management and Budget, approval numbers 3150-0044 and 3150-0014, respectively. The NRC may not conduct or sponsor, and a person is not required to respond to, a collection of information unless it displays a currently valid OMB control number.

As discussed in Regulatory Guide 8.29, exposure to any level of radiation is assumed to carry with it a certain amount of risk. In the absence of scientific certainty regarding the relationship between low dose exposure and health effects, and as a conservative assumption for radiation protection purposes, the scientific community generally assumes that any exposure to ionizing radiation may cause undesirable biological effects and that the likelihood of these effects increases as the dose increases. At the occupational dose limit for the whole body of 5 rem (50 mSv) per year, the risk is believed to be very low.

The magnitude of risk of childhood cancer following in utero exposure is uncertain in that both negative and positive studies have been reported. The data from these studies "are consistent with a lifetime cancer risk resulting from exposure during gestation which is two to three times that for the adult." The NRC has reviewed the available scientific literature and has concluded that the 0.5 rem (5

---

<sup>2</sup>Material in Appendix B-1 is extracted from Revision 3 to Regulatory Guide 8.13.

mSv) limit specified in 10 CFR 20.1208 provides an adequate margin of protection for the embryo/fetus. This dose limit reflects the desire to limit the total lifetime risk of leukemia and other cancers associated with radiation exposure during pregnancy.

In order for a pregnant worker to take advantage of the lower exposure limit and dose monitoring provisions specified in 10 CFR Part 20, the woman must declare her pregnancy in writing to the licensee. A form letter for declaring pregnancy is provided in this guide or the licensee may use its own form letter for declaring pregnancy. A separate written declaration should be submitted for each pregnancy.

### **1. Who Should Receive Instruction**

Female workers who require training under 10 CFR 19.12 should be provided with the information contained in this guide. In addition to the information contained in Regulatory Guide 8.29, this information may be included as part of the training required under 10 CFR 19.12.

### **2. Providing Instruction**

The occupational worker may be given a copy of this guide with its Appendix, an explanation of the contents of the guide, and an opportunity to ask questions and request additional information. The information in this guide and Appendix should also be provided to any worker or supervisor who may be affected by a declaration of pregnancy or who may have to take some action in response to such a declaration.

Classroom instruction may supplement the written information. If the licensee provides classroom instruction, the instructor should have some knowledge of the biological effects of radiation to be able to answer questions that may go beyond the information provided in this guide. Videotaped presentations may be used for classroom instruction. Regardless of whether the licensee provides classroom training, the licensee should give workers the opportunity to ask questions about information contained in this Regulatory Guide 8.13. The licensee may take credit for instruction that the worker has received within the past year at other licensed facilities or in other courses or training.

### **3. Licensee's Policy on Declared Pregnant Women**

The instruction provided should describe the licensee's specific policy on declared pregnant women, including how those policies may affect a woman's work situation. In particular, the instruction should include a description of the licensee's policies, if any, that may affect the declared pregnant woman's work situation after she has filed a written declaration of pregnancy consistent with 10 CFR 20.1208.

The instruction should also identify who to contact for additional information as well as identify who should receive the written declaration of pregnancy. The recipient of the woman's declaration may be identified by name (e.g., John Smith), position (e.g., immediate supervisor, the radiation safety officer), or department (e.g., the personnel department).

### **4. Duration of Lower Dose Limits for the Embryo/ Fetus**

The lower dose limit for the embryo/fetus should remain in effect until the woman withdraws the declaration in writing or the woman is no longer pregnant. If a declaration of pregnancy is withdrawn, the dose limit for the embryo/fetus would apply only to the time from the estimated date of conception until the time the declaration is withdrawn. If the declaration is not withdrawn, the written declaration may be considered expired one year after submission.

### **5. Substantial Variations Above a Uniform Monthly Dose Rate**

According to 10 CFR 20.1208(b), "The licensee shall make efforts to avoid substantial variation above a uniform monthly exposure rate to a declared pregnant woman so as to satisfy the limit in paragraph (a) of this section," that is, 0.5 rem (5 mSv) to the embryo/fetus. The National Council on Radiation Protection and Measurements (NCRP) recommends a monthly equivalent dose limit of 0.05 rem (0.5 mSv) to the embryo/ fetus once the pregnancy is known. In view of the NCRP recommendation, any monthly dose of less than 0.1 rem (1 mSv) may be considered as not a substantial variation above a uniform monthly dose rate and as such will not require licensee justification. However, a monthly dose greater than 0.1 rem (1 mSv) should be justified by the licensee.

## QUESTIONS AND ANSWERS CONCERNING PRENATAL RADIATION EXPOSURE

### 1. Why am I receiving this information?

The NRC's regulations (in 10 CFR 19.12, "Instructions to Workers") require that licensees instruct individuals working with licensed radioactive materials in radiation protection as appropriate for the situation. The instruction below describes information that occupational workers and their supervisors should know about the radiation exposure of the embryo/fetus of pregnant women.

The regulations allow a pregnant woman to decide whether she wants to formally declare her pregnancy to take advantage of lower dose limits for the embryo/ fetus. This instruction provides information to help women make an informed decision whether to declare a pregnancy.

### 2. If I become pregnant, am I required to declare my pregnancy?

No. The choice whether to declare your pregnancy is completely voluntary. If you choose to declare your pregnancy, you must do so in writing and a lower radiation dose limit will apply to your embryo/fetus. If you choose not to declare your pregnancy, you and your embryo/fetus will continue to be subject to the same radiation dose limits that apply to other occupational workers.

### 3. If I declare my pregnancy in writing, what happens?

If you choose to declare your pregnancy in writing, the licensee must take measures to limit the dose to your embryo/fetus to 0.5 rem (5 millisievert) during the entire pregnancy. This is one-tenth of the dose that an occupational worker may receive in a year. If you have already received a dose exceeding 0.5 rem (5 mSv) in the period between conception and the declaration of your pregnancy, an additional dose of 0.05 rem (0.5 mSv) is allowed during the remainder of the pregnancy. In addition, 10 CFR 20.1208, "Dose to an Embryo/ Fetus," requires licensees to make efforts to avoid substantial variation above a uniform monthly dose rate so that all the 0.5 rem (5 mSv) allowed dose does not occur in a short period during the pregnancy.

This may mean that, if you declare your pregnancy, the licensee may not permit you to do some of your normal job functions if those functions would have allowed you to receive more than 0.5 rem, and you may not be able to have some emergency response responsibilities.

### 4. Why do the regulations have a lower dose limit for the embryo/fetus of a declared pregnant woman than for a pregnant worker who has not declared?

A lower dose limit for the embryo/fetus of a declared pregnant woman is based on a consideration of greater sensitivity to radiation of the embryo/fetus and the involuntary nature of the exposure. Several scientific advisory groups have recommended that the dose to the embryo/fetus be limited to a fraction of the occupational dose limit.

### 5. What are the potentially harmful effects of radiation exposure to my embryo/fetus?

The occurrence and severity of health effects caused by ionizing radiation are dependent upon the type and total dose of radiation received, as well as the time period over which the exposure was received. See Regulatory Guide 8.29, "Instruction Concerning Risks from Occupational Exposure", for more information. The main concern is embryo/fetal susceptibility to the harmful effects of radiation such as cancer.

### 6. Are there any risks of genetic defects?

Although radiation injury has been induced experimentally in rodents and insects, and in the experiments was transmitted and became manifest as hereditary disorders in their offspring, radiation has not been identified as a cause of such effect in humans. Therefore, the risk of genetic effects attributable to radiation exposure is speculative. For example, no genetic effects have been documented in any of the Japanese atomic bomb survivors, their children, or their grandchildren.

### 7. What if I decide that I do not want any radiation exposure at all during my pregnancy?

You may ask your employer for a job that does not involve any exposure at all to occupational radiation dose, but your employer is not obligated to provide you with a job involving no radiation exposure. Even if you receive no occupational exposure at all, your embryo/ fetus will receive some radiation dose (on average 75 mrem (0.75 mSv)) during your pregnancy from natural background radiation.

The NRC has reviewed the available scientific literature and concluded that the 0.5 rem (5 mSv) limit provides an adequate margin of protection for the embryo/fetus. This dose limit reflects the desire to limit the total lifetime risk of leukemia and other cancers. If this dose limit is exceeded, the total lifetime risk of cancer to the embryo/fetus may increase incrementally. However, the decision on what level of risk to accept is yours. More detailed information on potential risk to the embryo/fetus from radiation exposure can be found in various references.

**8. What effect will formally declaring my pregnancy have on my job status?**

Only the licensee can tell you what effect a written declaration of pregnancy will have on your job status. As part of your radiation safety training, the licensee should tell you the company's policies with respect to the job status of declared pregnant women. In addition, before you declare your pregnancy, you may want to talk to your supervisor or your radiation safety officer and ask what a declaration of pregnancy would mean specifically for you and your job status.

In many cases you can continue in your present job with no change and still meet the dose limit for the embryo/fetus. For example, most commercial power reactor workers (approximately 93%) receive, in 12 months, occupational radiation doses that are less than 0.5 rem (5 mSv). The licensee may also consider the likelihood of increased radiation exposures from accidents and abnormal events before making a decision to allow you to continue in your present job.

If your current work might cause the dose to your embryo/fetus to exceed 0.5 rem (5 mSv), the licensee has various options. It is possible that the licensee can and will make a reasonable accommodation that will allow you to continue performing your current job, for example, by having another qualified employee do a small part of the job that accounts for some of your radiation exposure.

**9. What information must I provide in my written declaration of pregnancy?**

You should provide, in writing, your name, a declaration that you are pregnant, the estimated date of conception (only the month and year need be given), and the date that you give the letter to the licensee. A form letter that you can use is included at the end of these questions and answers. You may use that letter, use a form letter the licensee has provided to you, or write your own letter.

**10. To declare my pregnancy, do I have to have documented medical proof that I am pregnant?**

NRC regulations do not require that you provide medical proof of your pregnancy. However, NRC regulations do not preclude the licensee from requesting medical documentation of your pregnancy, especially if a change in your duties is necessary in order to comply with the 0.5 rem (5 mSv) dose limit.

**11. Can I tell the licensee orally rather than in writing that I am pregnant?**

No. The regulations require that the declaration must be in writing.

**12. If I have not declared my pregnancy in writing, but the licensee suspects that I am pregnant, do the lower dose limits apply?**

No. The lower dose limits for pregnant women apply only if you have declared your pregnancy in writing. The United States Supreme Court has ruled (in *United Automobile Workers International Union v. Johnson Controls, Inc.*, 1991) that "Decisions about the welfare of future children must be left to the parents who conceive, bear, support, and raise them rather than to the employers who hire those parents." The Supreme Court also ruled that your employer may not restrict you from a specific job "because of concerns about the next generation." Thus, the lower limits apply only if you choose to declare your pregnancy in writing.

**13. If I am planning to become pregnant but am not yet pregnant and I inform the licensee of that in writing, do the lower dose limits apply?**

No. The requirement for lower limits applies only if you declare in writing that you are already pregnant.

**14. What if I have a miscarriage or find out that I am not pregnant?**

If you have declared your pregnancy in writing, you should promptly inform the licensee in writing that you are no longer pregnant. However, if you have not formally declared your pregnancy in writing, you need not inform the licensee of your non-pregnant status.

**15. How long is the lower dose limit in effect?**

The dose to the embryo/fetus must be limited until you withdraw your declaration in writing or you inform the licensee in writing that you are no longer pregnant. If the declaration is not withdrawn, the written declaration may be considered expired one year after submission.

**16. If I have declared my pregnancy in writing, can I revoke my declaration of pregnancy even if I am still pregnant?**

Yes, you may. The choice is entirely yours. If you revoke your declaration of pregnancy, the lower dose limit for the embryo/fetus no longer applies.

**17. What if I work under contract at a licensed facility?**

The regulations state that you should formally declare your pregnancy to the licensee in writing. The licensee has the responsibility to limit the dose to the embryo/fetus.

**18. Where can I get additional information?**

The Radiation Safety Office has a list of references which contain helpful information. Additionally, NRC Regulatory Guide 8.29, "Instruction Concerning Risks from Occupational Radiation Exposure," (Appendix B-3) for general information on radiation risks.

For information on legal aspects, see, "The Rock and the Hard Place: Employer Liability to Fertile or Pregnant Employees and Their Unborn Children -- What Can the Employer Do?" which is an article in the journal *Radiation Protection Management*.

You may telephone the NRC Headquarters at (301) 415-7000. Legal questions should be directed to the Office of the General Counsel, and technical questions should be directed to the Division of Industrial and Medical Nuclear Safety.

You may also telephone the NRC Regional Offices at the following numbers: Region I, (610) 337-5000; Region II, (404) 562-4400; Region III, (630) 829-9500; and Region IV, (817) 860-8100. Legal questions should be directed to the Regional Counsel, and technical questions should be directed to the Division of Nuclear Materials Safety.



## FORM LETTER FOR DECLARING PREGNANCY

This form letter is provided for your convenience. To make your written declaration of pregnancy, you may fill in the blanks in this form letter, you may use a form letter the licensee has provided to you, or you may write your own letter.

---

### DECLARATION OF PREGNANCY

To:

(Name of your supervisor or other employer representative)

In accordance with the NRC's regulations at 10 CFR 20.1208, "Dose to an Embryo/Fetus," I am declaring that I am pregnant. I believe I became pregnant in \_\_\_\_\_ (only the month and year need be provided).

I understand the radiation dose to my embryo/fetus during my entire pregnancy will not be allowed to exceed 0.5 rem (5 millisievert) (unless that dose has already been exceeded between the time of conception and submitting this letter). I also understand that meeting the lower dose limit may require a change in job or job responsibilities during my pregnancy.

\_\_\_\_\_  
(Your signature)

\_\_\_\_\_  
(Your name printed)

\_\_\_\_\_  
(Date)

## **Appendix D-2 EXCERPT FROM US NRC REGULATORY GUIDE 8.13 – INSTRUCTION CONCERNING PRENATAL RADIATION EXPOSURE<sup>3</sup>**

It has been known since 1906 that cells that are dividing very rapidly and are undifferentiated in their structure and function are generally more sensitive to radiation. In the embryo stage, cells meet both these criteria and thus would be expected to be highly sensitive to radiation. Furthermore, there is direct evidence that the embryo/fetus is radiosensitive. There is also evidence that it is especially sensitive to certain radiation effects during certain periods after conception, particularly during the first 2 to 3 months after conception when a woman may not be aware that she is pregnant.

Title 10 Code of Federal Regulations (CFR) Part 20 places different radiation dose limits on workers who are minors than on adult workers. Workers under the age of 18 are limited to one-tenth of the adult radiation dose limits. However, the present NRC regulations do not establish dose limits specifically for the embryo/fetus unless the worker "declares" her pregnancy. Then the fetal limit is 500 millirem.

The present limit on the radiation dose that can be received on the job is 5,000 millirem per year. Working minors (those under 18) are limited to a dose equal to one-tenth that of adults, 500 millirem per year.

Because of the sensitivity of the unborn child, the National Council on Radiation Protection and Measurements (NCRP) has recommended that the dose equivalent to the unborn child from occupational exposure of the expectant mother be limited to 500 millirems for the entire pregnancy. The 1987 Presidential guidance specifies an effective dose equivalent limit of 500 millirems to the unborn child if the pregnancy has been declared by the mother; the guidance also recommends that substantial variations in the rate of exposure be avoided. The NRC adopted the above limits in § 20.208 of 10 CFR Part 20.

In 1971, the NCRP commented on the occupational exposure of fertile women and suggested that fertile women should be employed only where the annual dose would be unlikely to exceed 2 or 3 rems and would be accumulated at a more or less steady rate. In 1977, the ICRP recommended that, when pregnancy has been diagnosed, the woman work only where it is unlikely that the annual dose would exceed 0.30 of the dose-equivalent limit of 5 rems. In other words, the ICRP has recommended that pregnant women not work where the annual dose might exceed 1.5 rem.

### **Effects on the Embryo/Fetus of Exposure to Radiation and Other Environmental Hazards**

In order to decide whether to continue working while exposed to ionizing radiation during her pregnancy, a woman should understand the potential effects on an embryo/fetus, including those that may be produced by various environmental risks such as smoking and drinking. This will allow her to compare these risks with those produced by exposure to ionizing radiation.

Table 1 provides information on the potential effects resulting from exposure of an embryo/fetus to radiation and nonradiation risks. The second column gives the rate at which the effect is produced by natural causes in terms of the number per thousand cases. The fourth column gives the number of additional effects per thousand cases believed to be produced by exposure to the specified amount of the risk factor.

The following section discusses the studies from which the information in Table 1 was derived. The results of exposure of the embryo/fetus to the risk factors and the dependence on the amount of the exposure are explained.

### **Radiation Risks**

Childhood Cancer. Numerous studies of radiation-induced childhood cancer have been performed, but a number of them are controversial. The National Academy of Science (NAS) BEIR report reevaluated the data from these studies and even reanalyzed the results. Some of the strongest support for a casual relationship is provided by twin data from the Oxford survey. For maternal radiation doses of 1,000

---

<sup>3</sup>Material in Appendix B-3 is extracted from Regulatory Guide 8.13, Revision 2.

millirems, the excess number of cancer deaths (above those occurring from natural causes) was found to be 0.6 death per thousand children.

Mental Retardation and Abnormal Smallness of the Head (Microcephaly). Studies of Japanese children who were exposed while in the womb to the atomic bomb radiation at Hiroshima and Nagasaki have shown evidence of both small head size and mental retardation. Most of the children were exposed to radiation doses in the range of 1 to 50 rads. The importance of the most recent studies lies in the fact that investigators were able to show that the gestational age (age of the embryo/ fetus after conception) at the time the children were exposed was a critical factor. The approximate risk of small head size as a function of gestational age is shown in Table 1. For a radiation dose of 1,000 millirems at 4 to 7 weeks after conception, the excess cases of small head size was 5 per thousand; at 8 to 11 weeks, it was 9 per thousand.

In another study, the highest risk of mental retardation occurred during the 8 to 15 week period after conception. A recent EPA study has calculated that excess cases of mental retardation per live birth lie between 0.5 and 4 per thousand per rad.

Genetic Effects. Radiation-induced genetic effects have not been observed to date in humans. The largest source of material for genetic studies involves the survivors of Hiroshima and Nagasaki, but the 77,000 births that occurred among the survivors showed no evidence of genetic effects. For doses received by the pregnant worker in the course of employment considered in this guide, the dose received by the embryo/fetus apparently would have a negligible effect on descendants.

### **Nonradiation Risks**

Occupation. A recent study involving the birth records of 130,000 children in the State of Washington indicates that the risk of death to the unborn child is related to the occupation of the mother. Workers in the metal industry, the chemical industry, medical technology, the wood industry, the textile industry, and farms exhibited stillbirths or spontaneous abortions at a rate of 90 per thousand above that of workers in the control group, which consisted of workers in several other industries.

Alcohol. It has been recognized since ancient times that alcohol consumption had an effect on the unborn child. Carthaginian law forbade the consumption of wine on the wedding night so that a defective child might not be conceived. Recent studies have indicated that small amounts of alcohol consumption have only the minor effect of reducing the birth weight slightly, but when consumption increases to 2 to 4 drinks per day, a pattern of abnormalities called the fetal alcohol syndrome (FAS) begins to appear. This syndrome consists of reduced growth in the unborn child, faulty brain function, and abnormal facial features. There is a syndrome that has the same symptoms as full-blown FAS that occurs in children born to mothers who have not consumed alcohol. This naturally occurring syndrome occurs in about 1 to 2 cases per thousand.

For mothers who consume 2 to 4 drinks per day, the excess occurrences number about 100 per thousand; and for those who consume more than 4 drinks per day, excess occurrences number 200 per thousand. The most sensitive period for this effect of alcohol appears to be the first few weeks after conception, before the mother-to-be realizes she is pregnant. Also, 17% or 170 per thousand of the embryo/fetuses of chronic alcoholics develop FAS and die before birth. FAS was first identified in 1973 in the United States where less than full-blown effects of the syndrome are now referred to as fetal alcohol effects (FAE).

Smoking. Smoking during pregnancy causes reduced birth weights in babies amounting to 5 to 9 ounces on the average. In addition, there is an increased risk of 5 infant deaths per thousand for mothers who smoke less than one pack per day and 10 infant deaths per thousand for mothers who smoke one or more packs per day.

Miscellaneous. Numerous other risks affect the embryo/fetus, only a few of which are touched upon here. Most people are familiar with the drug thalidomide (a sedative given to some pregnant women), which causes children to be born with missing limbs, and the more recent use of the drug diethylstilbestrol (DES), a synthetic estrogen given to some women to treat menstrual disorders, which produced vaginal cancers in the daughters born to women who took the drug. Living at high altitudes

also gives rise to an increase in the number of low-birth-weight children born, while an increase in Down's Syndrome occurs in children born to mothers who are over 35 years of age. The rapid growth in the use of ultrasound in recent years has sparked an ongoing investigation into the risks of using ultrasound for diagnostic procedures.

Table 1. Effects of Risk Factors on Pregnancy Outcome

Effect	Number Occurring from Natural Causes	Risk Factor	Excess Occurrence from Risk Factor
<b>RADIATION RISK</b>			
<b>Childhood Cancer</b>			
Cancer death in children	1.4 per thousand	Radiation dose of 1000 mrem received before birth	0.6 per thousand
<b>Abnormalities</b>		Radiation dose of 1000 mrem received during specific periods after conception:	
Small head size	40 per thousand	4-7 weeks after conception	5 per thousand
Small head size	40 per thousand	8-11 weeks after conception	9 per thousand
Mental retardation	4 per thousand	Radiation dose of 1000 mrem received 8 to 15 weeks after conception	4 per thousand
<b>NON-RADIATION RISKS</b>			
<b>Occupation</b>			
Stillbirth or spontaneous abortion	200 per thousand	Work in high-risk occupations (see text)	90 per thousand
<b>Alcohol Consumption</b>			
Fetal alcohol syndrome	1 to 2 per thousand	2 - 4 drinks per day	100 per thousand
Fetal alcohol syndrome	1 to 2 per thousand	More than 4 drinks per day	200 per thousand
Fetal alcohol syndrome	1 to 2 per thousand	Chronic alcoholic (more than 10 drinks per day)	350 per thousand
Perinatal infant death (around time of birth)	23 per thousand	Chronic alcoholic (more than 10 drinks per day)	170 per thousand
<b>Smoking</b>			
Perinatal infant death	23 per thousand	Less than 1 pack per day	5 per thousand
Perinatal infant death	23 per thousand	One pack or more per day	10 per thousand

### Possible Health Risks to Children of Women who are Exposed to Radiation during Pregnancy

During pregnancy, you should be aware of things in your surroundings or in your style of life that could affect your unborn child. For those of you who work in or visit areas designated as Restricted Areas (where access is controlled to protect individuals from being exposed to radiation and radioactive materials), it is desirable that you understand the biological risks of radiation to your unborn child.

Everyone is exposed daily to various kinds of radiation: heat, light, ultraviolet, microwave, ionizing, and so on. For the purposes of this guide, only ionizing radiation (such as x-rays, gamma rays, neutrons, and other high-speed atomic particles) is considered. Actually, everything is radioactive and all human activities involve exposure to radiation. People are exposed to different amounts of natural "background" ionizing radiation depending on where they live. Radon gas in homes is a problem of growing concern. Natural background radiation comes from four sources: cosmic, terrestrial, radon, and internal. The average

Table 2. Avg. Medical Exposures

Procedure	Avg. Exposure
Normal Chest	10 millirem
Normal Dental	10 millirem
Rib Cage	140 millirem
Gall Bladder	170 millirem
Barium Enema	500 millirem
Pelvimetry	600 millirem

annual exposure of the U.S. population from natural background radiation is about 294 mrem/yr. Because of geographical and other factors, the exposure range of natural background radiation can range from approximately 200 mrem/yr to 5000 mrem/yr.

### **NRC Position**

NRC regulations and guidance are based on the conservative assumption that any amount of radiation, no matter how small, can have a harmful effect on an adult, child or unborn child. This assumption is said to be conservative because there are no data showing ill effects from small doses; the National Academy of Sciences recently expressed "uncertainty as to whether a dose, of say, 1 rad would have any effect at all". Although it is known that the unborn child is more sensitive to radiation than adults, particularly during certain stages of development, the NRC has not established a mandatory dose limit for protection of the unborn child. Such a limit could result in job discrimination for women of childbearing age and perhaps in the invasion of privacy (if pregnancy tests were required) if a separate regulatory dose limit were specified for the unborn child. Therefore, the NRC has taken the position that special protection of the unborn child should be voluntary and should be based on decisions made by workers (e.g., "declaring" pregnancy) and employers who are well informed about the risks involved.

For the NRC position to be effective, it is important that both the employee and the employer understand the risk to the unborn child from radiation received as a result of the occupational exposure of the mother. This document tries to explain the risk as clearly as possible and to compare it with other risks to the unborn child during pregnancy. It is hoped this will help pregnant employees balance the risk to the unborn child against the benefits of employment to decide if the risk is worth taking. This document also discusses methods of keeping the dose, and therefore the risk, to the unborn child as low as is reasonably achievable.

### **Radiation Dose Limits**

The NRC's present (whole body) limit on the radiation dose that can be received on the job is 1,250 millirems per quarter (3 months). Working minors (those under 18) are limited to a dose equal to one-tenth that of adults, 125 millirems per quarter.

Because of the sensitivity of the unborn child, the National Council on Radiation Protection and Measurements (NCRP) has recommended that the dose equivalent to the unborn child from occupational exposure of the expectant mother be limited to 500 millirems for the entire pregnancy. The 1987 Presidential guidance specifies an effective dose equivalent limit of 500 millirems to the unborn child if the pregnancy has been declared by the mother; the guidance also recommends that substantial variations in the rate of exposure be avoided. The NRC has adopted the 500 mrem limit for the entire pregnancy of "declared" pregnant workers.

### **Advice for Employee and Employer**

Although the risks to the unborn child are small under normal working conditions, it is still advisable to limit the radiation dose from occupational exposure to no more than 500 millirems for the total pregnancy. Employee and employer should work together to decide the best method for accomplishing this goal. Some methods that might be used include reducing the time spent in radiation areas, wearing some shielding over the abdominal area, and keeping an extra distance from radiation sources when possible. The employer or health physicist will be able to estimate the probable dose to the unborn child during the normal nine-month pregnancy period and to inform the employee of the amount. If the predicted dose exceeds 500 millirems, the employee and employer should work out schedules or procedures to limit the dose to the 500-millirem recommended limit.

It is important that the employee inform the employer of her condition as soon as she realizes she is pregnant if the dose to the unborn child is to be minimized.

### **Internal Hazards**

This document has been directed primarily toward a discussion of radiation doses received from sources outside the body. Workers should also be aware that there is a risk of radioactive material entering the

body in work places where unsealed radioactive material is used. Nuclear medicine clinics, laboratories, and certain manufacturers use radioactive material in bulk form, often as a liquid or a gas. A list of the commonly used materials and safety precautions for each is beyond the scope of this document, but certain general precautions might include the following:

- ✓ Do not smoke, eat, drink, or apply cosmetics around radioactive material
- ✓ Do not pipette solutions by mouth
- ✓ Use disposable gloves while handling radioactive material when feasible
- ✓ Wash hands after working around radioactive material
- ✓ Wear lab coats or other protective clothing whenever there is a possibility of spills.

Remember that the employer is required to have demonstrated that it will have safe procedures and practices before the NRC issues it a license to use radioactive material. Workers are urged to follow established procedures and consult the employer's radiation safety officer or health physicist whenever problems or questions arise.

# Appendix E SI UNITS AND CONVERSION FACTORS

## SI Units for Radioactive Materials

Prepared by

U.S. Council for Energy Awareness  
Committee on Radionuclides and Radiopharmaceuticals

Suite 400  
1776 I Street, N.W.  
Washington, D.C. 20006-3708  
202/293-0770

SI (Systeme International) units are now being used in many countries as the primary measurement system, including measurement of radioactivity, and the system is coming into use in the United States. Many journals (including those published by the American Medical Association) now require the use of SI units, and U.S. regulatory agencies are beginning to use SI units as well as conventional units in regulations. It is the policy of the United States Government that regulations should not impede the transition to SI units.

The U.S. Trade Act of 1988 includes a provision establishing federal policy to designate the metric system as the preferred measurement system for U.S. trade and commerce. It also requires all federal agencies to adopt the metric system for business-related activities by 1992, except where it proves impractical.

USCEA's Committee on Radionuclides and Radiopharmaceuticals is seeking to familiarize users of radioactive materials with SI units and to facilitate their use in the United States. The SI unit for radioactivity is the becquerel (Bq), and is defined as one nuclear transformation per second. It is a small unit when compared to the curie (Ci), and it is convenient to use multiples of the unit (see listing later in this brochure). It does have the convenience however of relating directly to count rate once corrections have been made for counting efficiency.

Most suppliers of radioactive materials including the National Institute of Standards Technology (NIST-formerly NBS) have been using dual units (curies and becquerels) in catalogs, product literature and labelling for some time and plan to do so for the foreseeable future. The European Economic Community (EEC) has stated that it will accept only SI units for radioactivity after 1999, and it is anticipated that all suppliers of radioactive products will be using only SI units at that time. In Canada, Atomic Energy Control Board documents produced since 1985 have been in SI units only, and conversion of regulations is in progress.

Other SI radiation measurement units are as follows:

## Exposure and Exposure Rate

The roentgen (R) is the traditional unit of measurement for exposure, the charge produced in air by  $\gamma$  or x-rays. The SI unit of exposure is coulombs per kilogram (C/kg) of air.

$$\begin{aligned}1 \text{ C/kg} &= 3876 \text{ R} \\1 \text{ R} &= 2.58 \times 10^{-4} \text{ C/kg}\end{aligned}$$

No special name has been given to this SI unit (C/kg) and since there is no convenient conversion to other SI units, it is seldom used. Instead, the observed dose rate in air, that is the air kerma rate, is typically being used as the SI measurement to replace exposure rate. An example of the use of air kerma rate is to define the radiation output from a sealed radioactive source in SI units. The SI units usually used to express air kerma rate are grays/second. In traditional units, exposure rate from a sealed source has typically been expressed in roentgens/hour at a distance of 1 meter from the source.

Charge as defined in exposure (charge produced in air by  $\gamma$  and X-radiation) does not include ionization produced by bremsstrahlung arising from absorption of electrons ( $\beta$ -particles). Apart from this difference, which is significant only with high energy  $\beta$ -particles, exposure is the ionization equivalent of air kerma. For a further discussion of air kerma see ICRU (International Commission on Radiation Units and Measurements) Report 33, 1980.

## Absorbed Dose

This is the amount of energy imparted to matter, and the rad has been the unit of measurement. The SI unit for absorbed dose is the gray (Gy).

$$\begin{aligned}1 \text{ Gray (Gy)} &= 100 \text{ rad} \\1 \text{ rad} &= 0.01 \text{ Gy}\end{aligned}$$

One roentgen of X-radiation in the energy range of 0.1-3 MeV produces 0.96 rad in tissue.

## Dose Equivalent

The dose equivalent is the absorbed dose multiplied by modifying factors such as a quality factor (accounts for the biological effect of different types of radiation) and the dose distribution factor. The rem is the unit of measurement that has been used, and the SI unit is the sievert (Sv).

$$\begin{aligned}1 \text{ Sv} &= 100 \text{ rem} \\1 \text{ rem} &= 0.01 \text{ Sv}\end{aligned}$$



We are giving advance notice of the change to SI Units to allow users time to become familiar with the new units. Do not hesitate to contact your supplier of radioactive materials or USCEA should you have any questions concerning SI units or the implementation of the change.

### CONVERSION TABLE FOR RADIOACTIVITY

Curie Units	Becquerel Units
$\mu\text{Ci}$	kBq
mCi	MBq
Ci	GBq
0.1	3.7
0.25	9.25
0.5	18.5
0.75	27.75
1	37
2	74
3	111
5	185
7	259
10	370
20	740
25	925

Curie Units	Becquerel Units
$\mu\text{Ci}$	MBq
mCi	GBq
Ci	TBq
50	1.85
60	2.22
100	3.7
200	7.4
250	9.25
500	18.5
800	29.6
1000	37

To convert from one unit to another, read across from one column to the other ensuring the units are in the same line of the column headings. For example:

From the first table:

$$0.1 \text{ mCi} = 3.7 \text{ MBq}$$

$$0.1 \text{ Ci} = 3.7 \text{ GBq}$$

From the second table:

$$50 \text{ mCi} = 1.85 \text{ GBq}$$

$$3.7 \text{ MBq} = 100 \mu\text{Ci}$$

## SI Units

1 becquerel (Bq) = 1 disintegration/second

1 becquerel =  $2.7027 \times 10^{-11}$  curie or  $\approx 27$  picocuries (pCi)

To convert becquerels to curies, divide the becquerel figure by  $37 \times 10^9$  (alternatively multiply the becquerel figure by  $2.7027 \times 10^{-11}$ )

1 curie (Ci) =  $3.7 \times 10^{10}$  disintegrations/second or 37 gigabecquerels (GBq)

To convert curies to becquerels, multiply the curie figure by  $37 \times 10^9$

Curie units that are frequently used:

1 Curie (Ci) = 1000 mCi

1 millicurie (mCi) = 1000  $\mu$ Ci

1 microcurie ( $\mu$ Ci) = 1000 nCi

1 nanocurie (nCi) = 1000 pCi (picocuries)

Becquerel units that are frequently used:

1 kilobecquerel (kBq) = 1000 Becquerels (Bq)

1 megabecquerel (MBq) = 1000 kBq

1 gigabecquerel (GBq) = 1000 MBq

1 terabecquerel (TBq) = 1000 GBq

1 Ci = 37 GBq

1 mCi = 37 MBq

1  $\mu$ Ci = 37 kBq

1 nCi = 37 Bq

## Appendix F GLOSSARY OF TERMS

**ABSORBED DOSE:** The energy imparted by ionizing radiation per unit mass of irradiated material.

**ABSORPTION:** The process by which radiation imparts some or all of its energy to any material through which it passes.

**ACTIVITY:** The rate of decay (disintegrations/time) of a given amount of radioactive material.

**ALARA:** An acronym for *As Low As Reasonably Achievable*. The principal that radiation doses should be kept as low as reasonably achievable taking into account economic and social factors.

**ALPHA PARTICLE ( $\alpha$ ):** A strongly ionizing particle emitted from the nucleus during radioactive decay which is equivalent to a helium nucleus (2 protons and 2 neutrons).

**ANNIHILATION RADIATION:** The two 511 keV photons produced when a positron combines with an electron resulting in the annihilation of the two particles.

**ANNUAL LIMIT ON INTAKE (ALI):** The derived limit for the amount of radioactive material taken into the body of an adult worker by inhalation or ingestion in a year. ALI is the smaller value of intake of a given radionuclide in a year by the reference man that would result in a CEDE of 5 rem or a CDE of 50 rem to any individual organ or tissue.

**ATOMIC MASS UNIT (amu):** One-twelfth the mass of a neutral atom of C-12. ( $1 \text{ amu} \approx 1.66 \times 10^{-24} \text{ g}$ )

**ATOMIC NUMBER (Z):** The number of protons in the nucleus of an atom.

**ATTENUATION:** Process by which a beam of radiation is reduced in intensity when passing through material – a combination of absorption and scattering processes.

**AUTORADIOGRAPH:** Record of radiation from radioactive material in an object, made by placing the object in close proximity to a photographic emulsion.

**BACKGROUND RADIATION:** Ionizing radiation arising from sources other than the one directly under consideration. Background radiation due to cosmic rays and the natural radioactivity of materials in the earth and building materials is always present.

**BECQUEREL (Bq):** The SI unit of activity equal to one disintegration per second. ( $1 \text{ Bq} = 2.7 \times 10^{-11} \text{ Ci}$ ).

**BETA PARTICLE ( $\beta$ ):** A charged particle emitted from the nucleus of an atom, having a mass equal to that of the electron, and a single positive or negative charge.

**BIOLOGICAL HALF-LIFE:** The time required for the body to eliminate by biological processes one-half of the amount of a substance which has entered it.

**BREMSSTRAHLUNG:** X-rays produced by the deceleration of charged particles passing through matter.

**CARRIER FREE:** An adjective applied to one or more radionuclides of an element in minute quantity, essentially undiluted with stable isotope carrier.

**COMMITTED DOSE EQUIVALENT (CDE):** The dose equivalent to organs or tissues of reference that will be received from an intake of radioactive material by an individual during the fifty-year period following the intake.

**COMMITTED EFFECTIVE DOSE EQUIVALENT (CEDE):** The sum of the products of the weighting factors applicable to each of the body organs or tissues that are irradiated and the CDE to these organs or tissues.

**COMPTON SCATTERING:** The elastic scattering of a photon by an essentially free electron.

**CONTAMINATION:** The deposition of radioactive material in any place where it is not desired, particularly in any place where its presence may be harmful.

**COUNT:** The external indication of a device designed to enumerate ionizing events.

**CURIE (Ci):** The unit of activity equal to  $3.7 \times 10^{10}$  disintegrations per second.

**DEEP-DOSE EQUIVALENT (DDE):** The dose equivalent at a tissue depth of 1 cm from external radiation.

**DOSE:** A general term denoting the quantity of radiation or energy absorbed in a specified mass.

**DOSE EQUIVALENT:** The product of the absorbed dose in tissue, quality factor, and all other necessary modifying factors at the location of interest.

**EFFECTIVE HALF-LIFE:** Time required for a radioactive nuclide in the body to be diminished fifty percent as a result of the combined action of radioactive decay and biological elimination.

Effective half-life =  $\frac{\text{Biological half-life} \times \text{Radioactive half-life}}{\text{Biological half-life} + \text{Radioactive half-life}}$

**EFFICIENCY:** The ratio of the count rate given by a radiation detection instrument and the actual disintegration rate of the material being counted.

**ELECTRON CAPTURE:** A mode of radioactive decay involving the capture of an orbital electron by its nucleus resulting in conversion of a proton to a neutron.

**ELECTRON VOLT (eV):** A unit of energy equal to the amount of energy gained by an electron passing through a potential difference of 1 volt.

**ERG:** A unit of energy.  $1 \text{ erg} = 6.24 \times 10^{11} \text{ eV}$ .

**ERYTHEMA:** An abnormal reddening of the skin due to distention of the capillaries with blood.

**EXPOSURE:** A measure of the ionizations produced in air by x-ray or gamma radiation. Sometimes used to mean dose.

**EYE DOSE EQUIVALENT:** The dose equivalent at a tissue depth of 0.3 cm from external radiation at the eye.

**FILM BADGE:** A packet of photographic film in a holder used for the approximate measurement of radiation dose.

**GAMMA:** Electromagnetic radiation (photon) of nuclear origin.

**GEIGER-MUELLER (G-M) COUNTER:** A radiation detection and measurement instrument.

**GRAY (Gy):** The SI unit of absorbed dose equal to 1 Joule/kilogram.

**HALF VALUE LAYER:** The thickness of any specified material necessary to reduce the intensity of an x-ray or gamma ray beam to one-half its original value.

**HEALTH PHYSICS:** The science concerned with the recognition, evaluation, and control of health hazards from ionizing radiation.

**ION:** Atomic particle, atom, or chemical radical bearing an electrical charge, either negative or positive.

**IONIZATION:** The process by which a neutral atom or molecule acquires either a positive or a negative charge.

**IONIZATION CHAMBER:** A radiation detection and measurement instrument.

**IONIZING RADIATION:** Any electromagnetic or particulate radiation capable of producing ions, directly or indirectly, by interaction with matter.

**ISOTOPES:** Nuclides having the same number of protons in the nuclei, and hence having the same atomic number, but differing in the number of neutrons, and therefore in mass number. Almost identical chemical properties exist among isotopes of a particular element.

**LABELLED COMPOUND:** A compound consisting, in part, of radioactive nuclides for the purpose of following the compound or its fragments through physical, chemical, or biological processes.

**LINEAR ENERGY TRANSFER (LET):** Average amount of energy lost per unit track length by the individual particles or photons in radiation passing through an absorbing medium.

**MASS NUMBER (A):** The number of protons and neutrons in the nucleus of an atom.

**NUCLIDE:** An atom characterized by its mass number, atomic number, and energy state of its nucleus.

**POSITRON:** A particle having a mass equal to that of an electron and a charge equal to that of an electron, but positive.

**QUALITY FACTOR (Q):** The LET-dependant modifying factor that is used to derive dose equivalent from absorbed dose.

**RAD:** The unit of absorbed dose equal to 100 erg/gram (or 0.01 Joule/kilogram).

**RADIATION:** Energy propagated through space or a material medium.

**RADIOACTIVE DECAY:** Disintegration of the nucleus of an unstable nuclide by the spontaneous emission of charged particles, neutrons, and/or photons.

**RADIOACTIVE HALF-LIFE:** The time required for a radioactive substance to lose fifty percent of its activity by decay.

**RADIOACTIVITY:** The property of certain nuclides of spontaneously disintegrating and emitting radiation.

**RADIONUCLIDE:** An unstable (radioactive) nuclide.

**RADIOTOXICITY:** The potential of a radioactive material to cause damage to living tissue by radiation after introduction into the body.

**REM:** The unit of dose equivalent equal to the absorbed dose in rad multiplied by any necessary modifying factors.

**ROENTGEN (R):** The unit of radiation exposure in air equal to  $2.58 \times 10^{-4}$  coulombs/kilogram.

**SCINTILLATION COUNTER:** A radiation detection and measurement instrument in which light flashes produced in a scintillator by ionizing radiation are converted into electrical pulses by a photomultiplier tube.

**SHALLOW-DOSE EQUIVALENT:** The dose equivalent at a tissue depth of 0.007 cm from external exposure of the skin or an extremity.

**SIEVERT (Sv):** The SI unit of dose equivalent equal to 1 Joule/kilogram.

**SPECIFIC ACTIVITY:** Total activity of a given radionuclide per unit mass or volume.

**SYSTEME INTERNATIONAL (SI):** A system of units adopted by the 11th General Conference on Weights and Measurements in 1960 and used in most countries of the world.

**THERMOLUMINESCENT DOSIMETER (TLD):** A dosimeter made of a crystalline material which is capable of both storing energy from absorption of ionizing radiation and releasing this energy in the form of visible light when heated. The amount of light released can be used as a measure of absorbed dose.

**TOTAL EFFECTIVE DOSE EQUIVALENT (TEDE):** The sum of the deep-dose equivalent (for external exposures) and the committed effective dose equivalent (for internal exposures).  $TEDE = DDE + CEDE$

**TOTAL ORGAN DOSE EQUIVALENT (TODE):** The sum of the DDE and the CDE to an organ or tissue.

**WEIGHTING FACTOR:** The proportion of the risk of stochastic effects for an organ or tissue when the whole body is irradiated uniformly.

**X-RAY:** Electromagnetic radiation (photon) of non-nuclear origin having a wavelength shorter than that of visible light.

## **Appendix G REFERENCES**

Basic Radiation Biology. D. J. Pizzarello and R. L. Witcofski; Lea & Febiger, 1967.

Basic Radiation Protection Criteria. National Council on Radiation Protection and Measurements (NCRP) Report No. 39; NCRP, 1971.

The Dictionary of Health Physics & Nuclear Sciences Terms. R. J. Borders; RSA Publications, 1991.

The Effects on Populations of Exposure to Low Levels of Ionizing Radiation: 1980. Committee on the Biological Effects of Ionizing Radiations (BEIR); National Academy Press, 1980.

Health Effects of Exposure to Low Levels of Ionizing Radiation. Committee on the Biological Effects of Ionizing Radiations (BEIR); National Academy Press, 1990.

The Health Physics and Radiological Health Handbook, Revised Edition. B. Shleien; Scinta, 1992.

The Health Physics and Radiological Health Handbook. B. Shleien; Nucleon Lectern Associates, 1984.

Influence of Dose and its Distribution in Time on Dose-Response Relationships for Low-LET Radiations. NCRP Report No. 64; NCRP, 1980.

Introduction to Health Physics. H. Cember; Pergamon Press, 1969.

The Physics of Radiology. H. E. Johns, and J. R. Cunningham; Thomas, 1978.

Radiation Biophysics. H. Andrews; Prentice-Hall, 1961.

Radiation Protection Design Guidelines for 0.1 - 100 MeV Particle Accelerator Facilities. NCRP Report No. 51; NCRP, 1977.

Radiation Protection Training Manual. A. Zea; University of Southern California.

Radiation Safety Training and Reference Manual. California Institute of Technology, 1996